

IBS PanelLine®

Design & Installation Guide

June 2026



BUILDING BETTER HOMES

Proudly Kiwi Owned and
Operated for over 30 years



☎ 0800 367 759

🌐 www.ibs.co.nz

✉ info@ibs.co.nz



SUSTAINABLE BUILDING PRODUCTS

Welcome to Independent Building Supplies (IBS), your trusted partner in the New Zealand building industry. Since our inception in 1993, IBS has been dedicated to sourcing and providing the highest quality building materials from around the globe. As a family business with four generations active in the building industry in New Zealand, we bring a wealth of experience and a deep commitment to excellence.

One of the key aspects that set IBS apart is our commitment to innovation. We are constantly on the lookout for new and improved building materials that can enhance the efficiency and effectiveness of construction projects. Our team of experts works closely with suppliers to bring cutting-edge products to the New Zealand market, ensuring that our customers have access to the latest advancements in building technology.

But our commitment to excellence doesn't stop at our products. At IBS, we pride ourselves on providing unparalleled customer service. Our knowledgeable and friendly team is always on hand to offer expert advice and support, helping you choose the right materials for your project.

ABOUT **IBS**

At IBS, we recognise that the foundation of any great building project lies in the quality of the materials used. That's why we meticulously select our suppliers, ensuring that every product meets our stringent standards for durability, performance, and sustainability. Our extensive range of offerings includes everything from plywood and panels to flooring and cladding, all tailored to meet the diverse needs of the New Zealand market.





*We seek to develop the most innovative, professional and profitable experience for our clients.
Our passion is for providing our customers with the best products, the best service, and the best experience*

In addition to our exceptional product range and customer service, IBS is also dedicated to sustainability. We recognise the importance of protecting our environment and are committed to sourcing eco-friendly building materials. Our sustainable product offerings help reduce the environmental impact of construction projects, allowing our customers to build responsibly without compromising on quality or performance.

IBS is more than just a supplier of building materials; we are a partner in your success. Our comprehensive range of services includes everything from product sourcing and logistics to technical support and training. We work closely with our customers to understand their unique needs and provide tailored solutions that help them achieve their objectives.

Join the countless builders, contractors, and homeowners who trust IBS for their building material needs. Discover the difference that quality, innovation, and exceptional service can make in your next project. Choose Independent Building Supplies – your partner in building excellence for over 30 years.

- IBS RigidRAP®
 - IBS RigidRAP®- XT
 - IBS EUROFloor
 - IBS Plyfloor
 - IBS FutureFloor™
 - IBS EUROLine
 - IBS FIBRE® Range
 - IBS Structural Ply
- IBS Builders Grade® Ply
 - IBS Formply
 - IBS Decorative Ply
 - IBS PanelLine®
 - IBS Showerline
 - IBS Softboard
 - IBS Hardboard
 - IBS Peg Board

Contents

1.	Introduction	6
1.1	Introduction	6
1.2	Scope	6
1.3	Sizes & Applications	6
1.4	Benefits	7
1.5	Supporting Info & Documents	7
2.	Best Practice	8
2.1	Health & Safety	8
2.2	Handling & Storage	8
2.3	Cutting	9
2.4	Drilling	9
2.5	Service Penetration	9
3.	Durability	10
3.1	Compliance	10
3.2	Responsibility	10
3.3	Conditions	10
3.4	Prohibited Uses	11
3.5	Defects	11
3.6	Differing Installation	11
4.	Design	12
4.1	Preparation	12
4.2	Sheet Fixing	12
4.3	Framing	13
4.4	Wall Steel Framing	13
4.5	Bracing Systems	14

5.	Installation	23
5.1	General Installation	23
5.2	Installing as a bracing element	23
5.3	Installing a wall bracing system	23
5.4	Installing as a wall or ceiling lining	24
5.5	Lining timber framed walls	24
5.6	Lining masonry walls	25
5.7	Lining ceilings	25
5.8	Steel Frame with Hold Downs	26
5.9	Sheet Fasteners	26
5.10	Panel Hold-Downs	27
5.11	IBS PanelLine® – Wall Bracing Systems	29
5.12	IBS PanelLine® Hold-Down Systems	32
6.	Finishing	36
6.1	Preparation	36
6.2	Sealants	36
6.3	Coating	36
7.	Care & Maintenance	39
8.	Warranty	40
9.	Technical Properties	44
10.	Additional Resources	45
10.1	Compliance and Information	45
10.2	Designing outside of scope	45
11.	Frequently Asked Questions	46
12.	Limitations	48
13.	Installation Checklist	51

NZBN 9429000097253

Contact us for more information or to talk to our team.

www.ibs.co.nz | 0800 367 759 | info@ibs.co.nz

1. Introduction

This document is intended for designers and installers to ensure that IBS PanelLine® is specified and installed correctly.

1.1 Introduction

IBS PanelLine® is specifically designed for the New Zealand market, combining modern manufacturing techniques with a classic colonial style and bracing solution.

This panel is more impact-resistant than other wall lining options, making it ideal for use as a dado line or as a full-length sheet. IBS supplies the MDF V-Groove PanelLine® Brace as an internal lining solution with added bracing capacity.

The panels have a V groove profile running the length of the panel for easy horizontal or vertical fixing. The sides have a tongue and groove for seamless width joints.

1.2 Scope

- In new buildings with framing that complies with the NZ Building Code (NZBC).
- In existing buildings where the designer or installer have assured themselves that the existing building is suitable for the intended building work.
- As a wall bracing element on timber framed buildings.

1.3 Sizes & Applications

TABLE 1 - IBS PanelLine® V-Groove MDF			
L x W x Thickness (mm)	Weight (kg)	IBS Product Code	GTIN
2440 x 1200 x 9	19.1	PAN092412V	09421028764728
2745 x 1200 x 9	21.5	PAN092712V	09421028764742
3660 x 1200 x 9	28.7	PAN093612V	09421028768504
3800 x 1200 x 9	29.8	PAN093812V	09421036230352

TABLE 2 - IBS PanelLine® Pre-Primed V - Groove MDF			
L x W x Thickness (mm)	Weight (kg)	IBS Product Code	GTIN
2440 x 1200 x 9	19.1	PPAN092412V	09421036230369
2745 x 1200 x 9	21.5	PPAN092712V	09421036230376

1.4 Benefits of IBS PanelLine®

- **Natural and Pre-Primed Options:** IBS PanelLine® MDF is available in both Natural and some sizes as a pre-primed option, providing flexibility and saving time on further finishing.
- **High Impact Resistance:** Designed to withstand high-traffic areas, this wall lining solution maintains its visual appeal and durability over time.
- **Versatile Applications:** Whether used as a dado line or as a full-length sheet, IBS PanelLine® MDF is perfect for internal wall bracing, full or partial wall lining, and ceiling lining.
- **Colonial Style Character:** The timeless colonial aesthetic adds a touch of elegance and sophistication to any space.
- **Meets AS/NZS 1859.2 Standards:** This product meets the rigorous standards outlined in AS/NZS 1859.2, ensuring both performance and compliance in various building applications.
- **MDF V-Groove PanelLine® Brace:** In addition to the standard panel, IBS offers the MDF V-Groove PanelLine® Brace, an internal lining solution with added bracing capacity to support the structural integrity of walls.
- **Flexible Installation:** The V-groove profile running the length of the panel allows for easy horizontal or vertical fixing, while the tongue-and-groove sides ensure seamless width joints, creating a flawless and cohesive appearance without visible seams.
- **Manufactured from Premium Grade MDF:** Made from high-quality MDF, IBS PanelLine® ensures strength, design flexibility, and ease of installation.
- **Use in Dry Areas:** As the product is made from MDF it is designed to be used in dry areas only, use our FIBRE V-Groove or V-Groove ply when you need to have a V-Groove look that may be subject to moisture.

1.5 Supporting Info & Documents

This document must be read in conjunction with the:

- IBS PanelLine® Maintenance and Warranty

All other information including any updates are available at www.ibs.co.nz.

2. Best Practice

2.1 Health & Safety

For information on Health & Safety, refer to:

- The Absolutely Essential Health and Safety Toolkit
- Worksafe New Zealand Quick Guide.

2.2 Handling & Storage

Loading and Unloading

Panels should be fully protected from the weather when they are transported. The storage area should be well ventilated and dry.

To ensure the compatibility of IBS Panelline® Brace with other construction materials, you will also need to store them at the installation site for at least 48 hours before you start work.

Transport to Site

Always drive the delivery vehicle as close as possible to the location where the panels are to be installed. When transporting the panels, it is essential to firmly secure the pallets to prevent the panels from sliding or moving while in transit.

Storage

Store the panels horizontally and lift them clear of the floor using dry bearers as supports.

The individual bearers should be of equal thickness, vertically aligned if they are supporting several layers and placed at not more than 800mm centres.

Stack the panels flush to minimise damage to protruding edges or overhanging corners. Try to avoid sliding panels on top of each other to prevent scratching on surface.

Site considerations:

- Selection of the right equipment for working from a height
- Safe working with ladders and stepladders
- Maintain a clear unobstructed work area
- Clear the work area of any obstructions before you start.
- Ensure each panel is well supported when you are cutting and fixing.
- Use a dust mask, safety glasses, ear protection, and wear appropriate clothing and footwear.
- Any offcuts or shavings should be removed without generating dust.

2.3 Cutting

IBS PanelLine® can be easily cut using a fine-tooth saw, whether by hand or with a power saw. When cutting, it's important to use a fine-tooth blade to ensure smooth edges and minimise chipping.

After cutting, the edges can be further smoothed and tidied up by using a hand plane or sandpaper, ensuring a clean and even finish.

Sanding:

Sanding is particularly useful for refining the edges and removing any roughness or imperfections left from the saw blade.

For a more polished appearance, consider applying a fine-grit sandpaper to achieve a smooth, professional edge suitable for various applications.

The panel edges can be easily hand-sanded with a flat block and 120-150-grit paper.

- Before you start make sure that the building is closed in and fully weathertight.
- Any fixings must be no closer than 10mm from the edge of each panel and no closer than 18mm from the end of each panel.
- Always leave to acclimatise in the room for 48 hours to achieve equilibrium moisture content.

2.4 Drilling

IBS PanelLine® fibre (MDF) boards should be drilled using tungsten carbide-tipped drills with point angles between 60° and 80°, as these are more efficient and preferred over the standard 120° type.

Pre-drilling pilot holes:

If you are fixing the panels with screws, we recommend drilling 2.4mm pilot holes to prevent splitting the wood. Drill the holes approximately 2-3mm deeper than the screw depth.

Do not overtighten screws as it will reduce their holding strength.

2.5 Service Penetration

Very often apertures need to be cut within a board in order to allow for penetration of services such as switchboxes, lights, access panels etc.

If using as a bracing panel make sure that the penetrations do not exceed 90 x 90mm and must be a minimum of 90 mm from any edge.

3. Durability

3.1 Compliance

IBS PanelLine® panels are designed to have a serviceable life of at least 50 years, provided they are kept dry throughout their service life. To ensure optimal performance and longevity, it is essential that the systems are maintained in strict accordance with the guidelines set out in BRANZ Appraisal No. 779 (2013). Regular inspection and maintenance, as outlined in the appraisal, will help preserve the integrity of the wall bracing systems and prevent any issues that could potentially affect their durability.

To minimise risk:

Use cutting tools equipped with dust extraction or suppression features whenever possible. Ensure proper ventilation in the work area. Protect against dust exposure by wearing suitable personal protective equipment, including safety goggles, protective clothing, and an approved respirator, such as a dust mask of at least type P1 or higher.

3.2 Responsibility

Designers and/or contractors responsible for the intended project should follow the details and recommendations specified in this manual.

It is also wise to keep in mind that all designs and constructions should comply with appropriate and relevant requirements of current legal building codes, regulations and standards, both domestic and international.

*The information provided in this installation guideline is valid at the time of publication.

3.3 Conditions

- IBS PanelLine® should not be installed if the moisture content of the supporting timber framing exceeds 18%.
- IBS PanelLine® is not recommended for use in areas subject to high moisture content or water splashes such as kitchens, bathrooms, toilets or laundries.
- The minimum framing dimensions must be 90 x 45 mm for external walls and 75 x 45 mm for nonstructural internal walls.
- Do not expose the sheets to temperatures of 50°C or greater for prolonged periods.

3.4 Prohibited Uses

Specifiers, designers and installers must ensure that any time that IBS PanelLine® is installed that it is only used when all conditions are met in relation to the local requirements as well as the current Building Code.

3.5 Defects

Before Installation, please ensure you check the panels for defects or damage.

3.6 Differing Installation

To ensure the warranty on the product remains valid, it is crucial to follow the design and installation guidelines provided. Failure to adhere to these instructions may result in the warranty being voided.



4. Design

4.1 Preparation

When specifying IBS PanelLine® the designer must ensure that the project falls within the specified scope.

The designer must also consider the following indicative list:

The building work

Compliance of the building with all relevant provisions of the NZBC, including but not limited to:

- Suitability of the existing building.
- Structural framing requirements – (short and long term).
- Other materials likely to affect the product's performance.

If IBS PanelLine® is specified as an internal bracing element, use the bracing ratings set out in Table 4 on page 28. The bracing values are based on timber framed walls being lined with IBS PanelLine®. Brace on one face only.

4.2 Sheet Fixing

Fittings you will need

When you are using IBS PanelLine® as a wall bracing element use the following fixings:

Bottom Plate Fixing: M12 bolt (anchor or screw) and 50 x 50 x 3mm washers, galvanised or stainless steel 25 x 0.9mm strap.

IBS PanelLine® should not be exposed to temperatures above 50°C for extended periods. Refer to appliance and fitting manufacturers information for installation details.

Wall Heights

The bracing units in table 4 are designed for 2.4m high walls.

For walls above 2.4m, a full sheet (e.g., 2.7m x 1.2m) can be used, or a part sheet (e.g., 0.3m x 1.2m) can be stacked above a full sheet. Fixings must be at least 10mm from the sheet edge and 18mm from the top and bottom edges. Nails should be flush with the sheet surface, and screws should be countersunk 0.5mm.

For walls over 2.4m, the bracing rating is calculated by multiplying the value in Table 4 by a factor of $f = 2.4/H$, where H is the wall height in metres. Walls lower than 2.4m are rated as if they were 2.4m high.

Sheet Fixing

For bracing applications

- 40 x 2.8mm hot-dipped galvanised flat-head clouts.
- 6g x 32mm, gold passivated countersunk, coarse thread woodscrews.

When you are installing the IBS PanelLine® Brace as a finished wall lining use the following:

- 40 x 2.0mm jolt-head nails with panel adhesive
- Mechanical gun-driven pins with panel adhesive (recommended)
- 6g x 32mm, gold passivated countersunk, coarse thread woodscrews

4.3 Framing

Sheets can be fixed to timber or light gauge steel framing and are also suitable for metal framing systems, typically used in commercial applications. Frames should be straight and accurate to ensure a flush surface for sheeting installation.

The best tolerance is between 3mm and 4mm over any 3000mm length of frame. Lining sheets will not correct severely warped or distorted frames, and any warping may remain visible after the decorative coating is applied.

4.4 Wall Steel Framing

Wall framing must comply with NZBC B1 Structure and NZBC B2 Durability. Steel framing should follow NASH Standard Part Two: May 2019 for Light Steel Framed Buildings.

C-section studs must have a minimum thickness of 0.75mm, a nominal depth of 87mm, and 35mm wide flanges.

4.5 Bracing Systems

System IBS-PL-01

IBS PanelLine® 600 x 2400 wall with No hold down

Wall construction:

- 90x45 MSG8 studs
- IBS PanelLine® on one side
- When fixing the bottom plate either use
 - 2/100x3.75mm hand driven nails 50mm from each corner or
 - 3/90x3.15 power driven nails evenly spaced
- When Fixing with Screws
 - 40x4.2mm (8 gauge), gold-passivated, counter sunk, coarse-thread woodscrews
 - Fixings to be at 150mm around the perimeter of the sheet
- When Fixing with Nails
 - 40x2.8mm hot-dipped galvanised fibre cement nails
 - Fixings to be at 150mm around the perimeter of the sheet
- When Fixing with Staples refer to page 32 figure 12 and below
 - 1.6mm (16 gauge) 10.5mm crown, 35mm leg or longer, galvanised staples
 - Fixings to be at 50mm, 100mm, 150mm from each corner and then 150mm there after around the perimeter of the sheet
 - Must be no closer than 10mm from the edge of the sheet and no closer than 18mm from the top and bottom edges of the sheet.
 - Driven at right angles
 - 0.5mm depth only to allow for filling
- No fixing on nogs or dwangs required

Figure 1

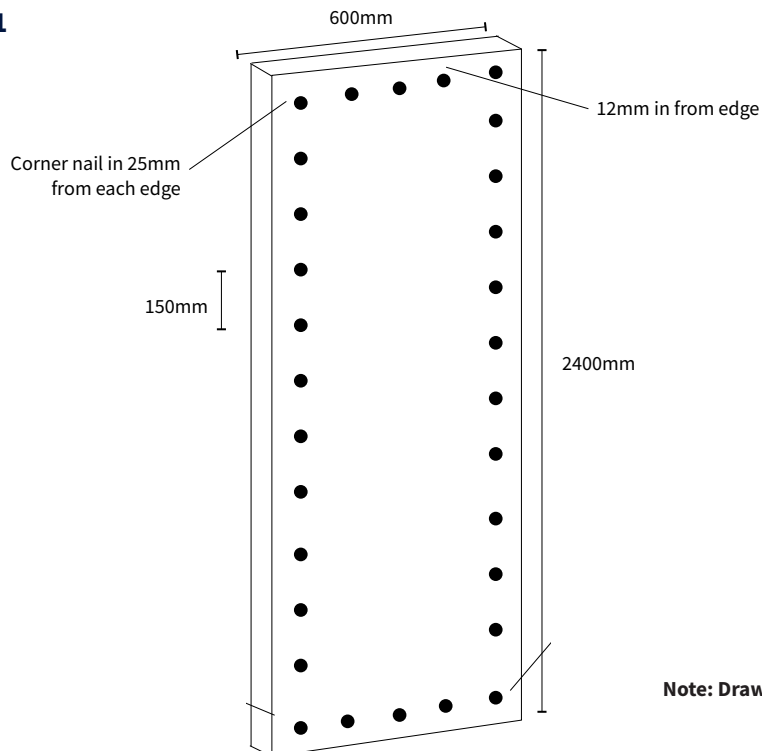

Note: Drawings are for illustration purposes only.

System IBS-PL-02

IBS PanelLine® 400 x 2400 with Gib® Handibrac® Hold downs on 2 sides

Wall construction:

- 90x45 MSG8 studs
- IBS PanelLine® on one side
- When Fixing with Screws
 - 40x4.2mm (8 gauge), gold-passivated, counter sunk, coarse-thread woodscrews,
 - Fixings to be at 150mm around the perimeter of the sheet
- When Fixing with Nails
 - 40x2.8mm hot-dipped galvanised fibre cement nails,
 - Fixings to be at 150mm around the perimeter of the sheet
- When Fixing with Staples refer to page 32 figure 12 and below
 - 1.6mm (16 gauge) 10.5mm crown, 35mm leg or longer, galvanised staples
 - Fixings to be 50mm, 100mm, 150mm maximum from each corner and then 150mm centres after that around the perimeter of the sheet
 - Must be no closer than 10mm from the edge of the sheet and no closer than 18mm from the top and bottom edges of the sheet.
 - Driven at right angles
 - 0.5mm depth only to allow for filling
- No fixing on nogs or dwangs required
- Gib® Handibrac® hold down brackets fixed to each end-to-end studs and to the bottom plate with hold down fixings as per the manufacturer's specifications

Figure 2

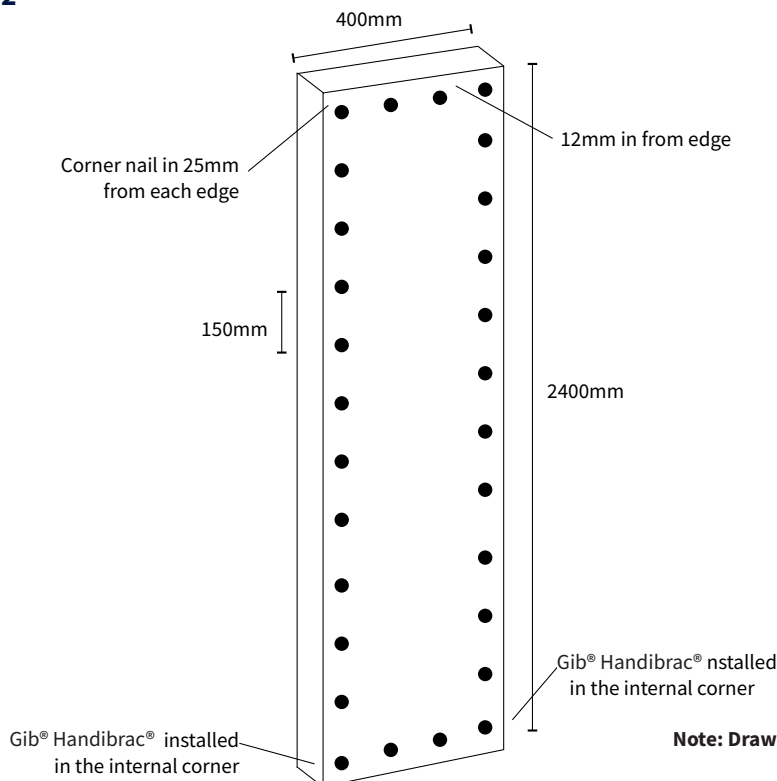

System IBS-PL-03

IBS PanelLine® 1200 x 2400 with Gib® Handibrac® Hold downs on 2 sides

Wall construction:

- 90x45 MSG8 studs
- IBS PanelLine® on one side
- When Fixing with Screws
 - 40x4.2mm (8 gauge), gold-passivated, counter sunk, coarse-thread woodscrews,
 - Fixings to be at 150mm around the perimeter of the sheet
 - Fixings to be at 300mm centres on the intermediate stud
- When Fixing with Nails
 - 40x2.8mm hot-dipped galvanised fibre cement nails,
 - Fixings to be at 150mm around the perimeter of the sheet
 - Fixings to be at 300mm centres on the intermediate stud
- When Fixing with Staples refer to page 32 figure 12 and below
 - 1.6mm (16 gauge) 10.5mm crown, 35mm leg or longer, galvanised staples
 - Fixings to be 50mm, 100mm, 150mm maximum from each corner and then 150mm centres after that around the perimeter of the sheet
 - Must be no closer than 10mm from the edge of the sheet and no closer than 18mm from the top and bottom edges of the sheet.
 - Fixings to be at 300mm centres on the intermediate stud
 - Driven at right angles
 - 0.5mm depth only to allow for filling
- No fixing on nogs or dwangs required
- Gib® Handibrac® hold down brackets fixed to each end-to-end studs and to the bottom plate with hold down fixings as per the manufacturer's specifications

Figure 3

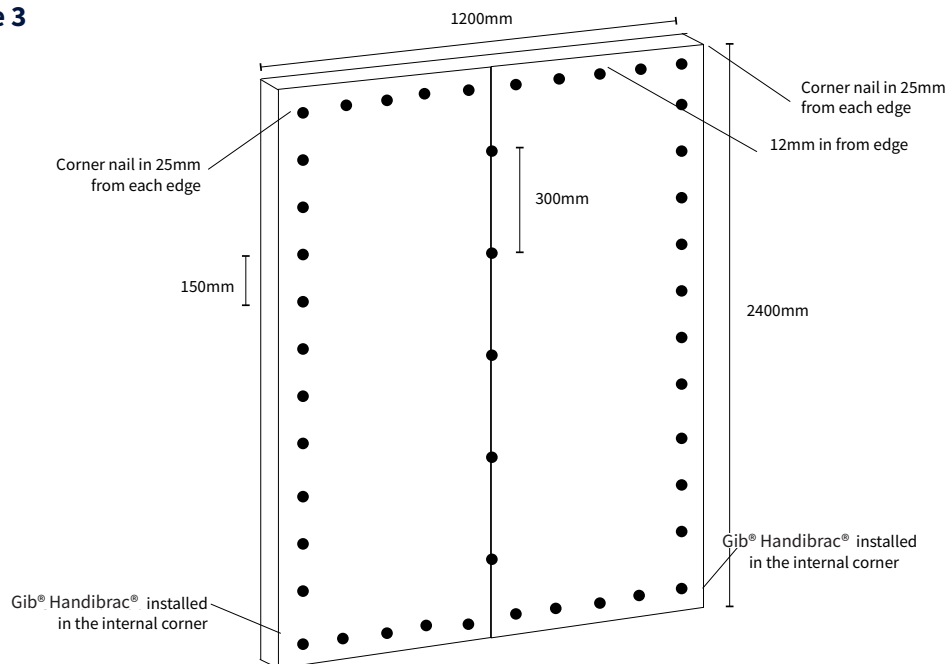

Note: Drawings are for illustration purposes only.

System IBS-PL-04

IBS PanelLine® 400 x 2400 with Gib® Handibrac® Hold downs on 2 sides with Finishing Nails

Wall construction:

- 90x45 MSG8 studs
- IBS PanelLine® on one side
- 1.6mm (16 gauge) 32mm or longer finish nails
- Fixings at 25mm, 50mm, 75mm, 100mm, 150mm from each corner and then at 150mm centres after that around the perimeter of the sheet
- Drive pressure to be set at 0.5mm depth to allow for filling
- No fixing on nogs or dwangs required
- Gib® Handibrac® hold down brackets fixed to each end-to-end studs and to the bottom plate with hold down fixings as per the manufacturer's specifications

Figure 4

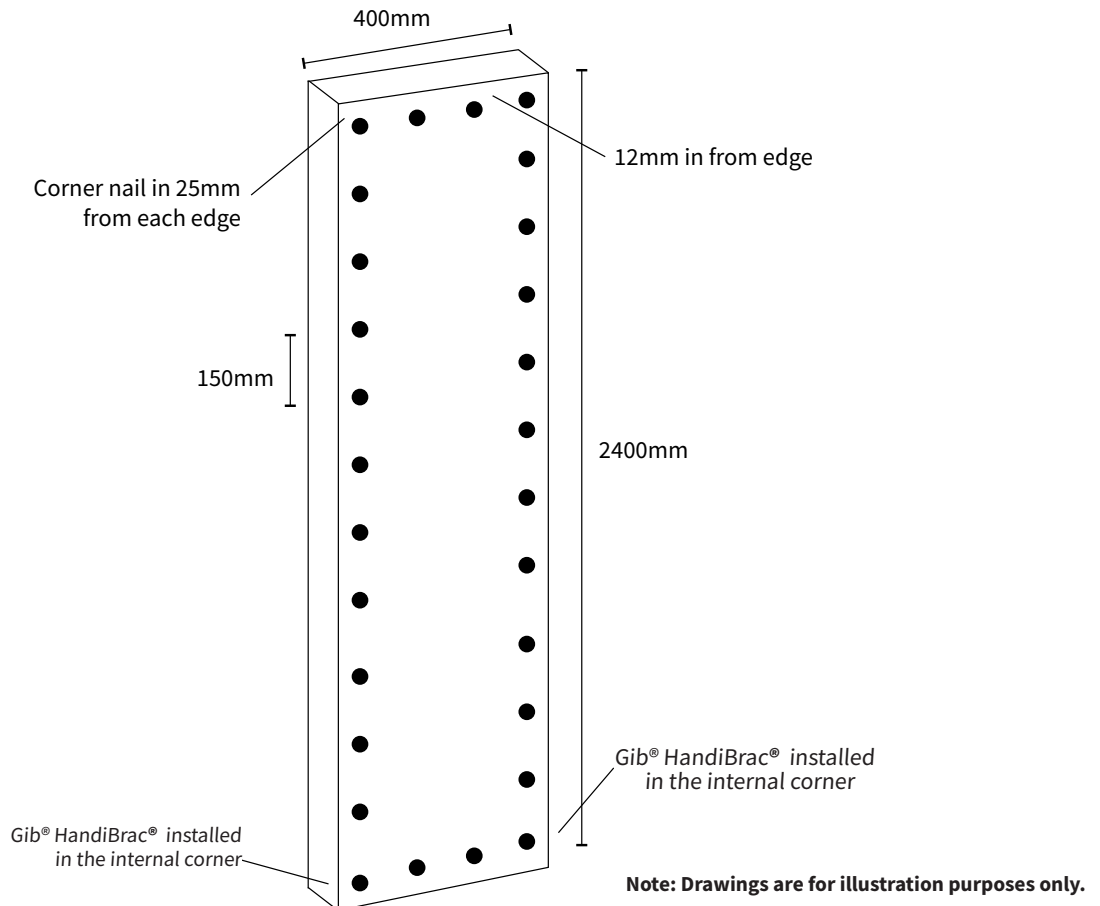

System IBS-PL-05

IBS PanelLine® 1200 x 2400 with Gib® Handibrac® Hold downs on 2 sides with Finishing Nails

Wall construction:

- 90x45 MSG8 studs
- IBS PanelLine® on one side
- 1.6mm (16 gauge) 32mm or longer finish nails
- Fixings at 25mm, 50mm, 75mm, 100mm, 150mm from each corner and then at 150mm centres after that around the perimeter of the sheet
- Fixings at 150mm centres to the intermediate studs
- Drive pressure to be set at 0.5mm depth to allow for filling
- No fixing on nogs or dwangs required
- Gib® Handibrac® hold down brackets fixed to each end-to-end studs and to the bottom plate with hold down fixings as per the manufacturer's specifications

Figure 5

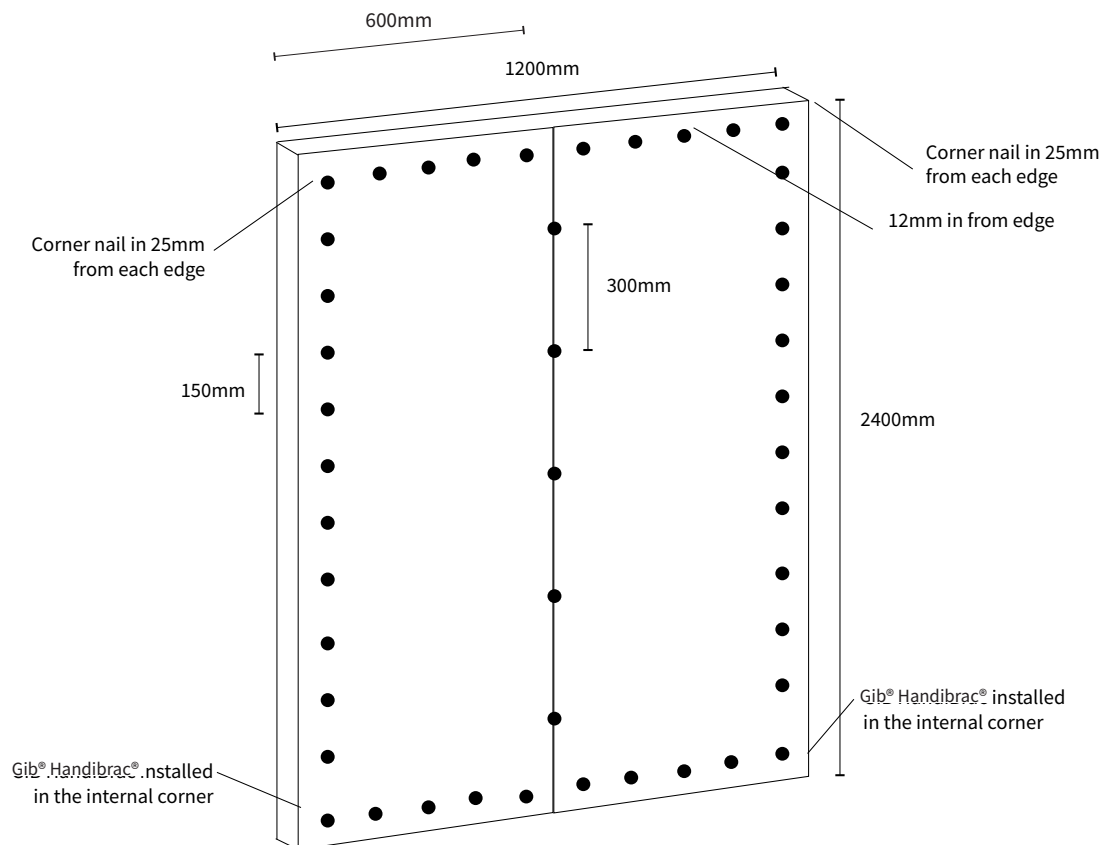

Note: Drawings are for illustration purposes only.

System IBS-PL-06

IBS PanelLine® 1200 x 2400 on one side and 10mm Gib® Plasterboard on the other side with Hold Downs

Wall construction:

- 90x45 MSG8 studs
- IBS PanelLine® on one side
- 10mm Gib® Plasterboard on the other side
- Fixing for PanelLine®
 - When Fixing with Screws
 - 40x4.2mm (8 gauge), gold-passivated, counter sunk, coarse-thread woodscrews,
 - Fixings to be at 150mm around the perimeter of the sheet
 - Fixings to be at 300mm centres on the intermediate stud
 - When Fixing with Staples

Figure 6

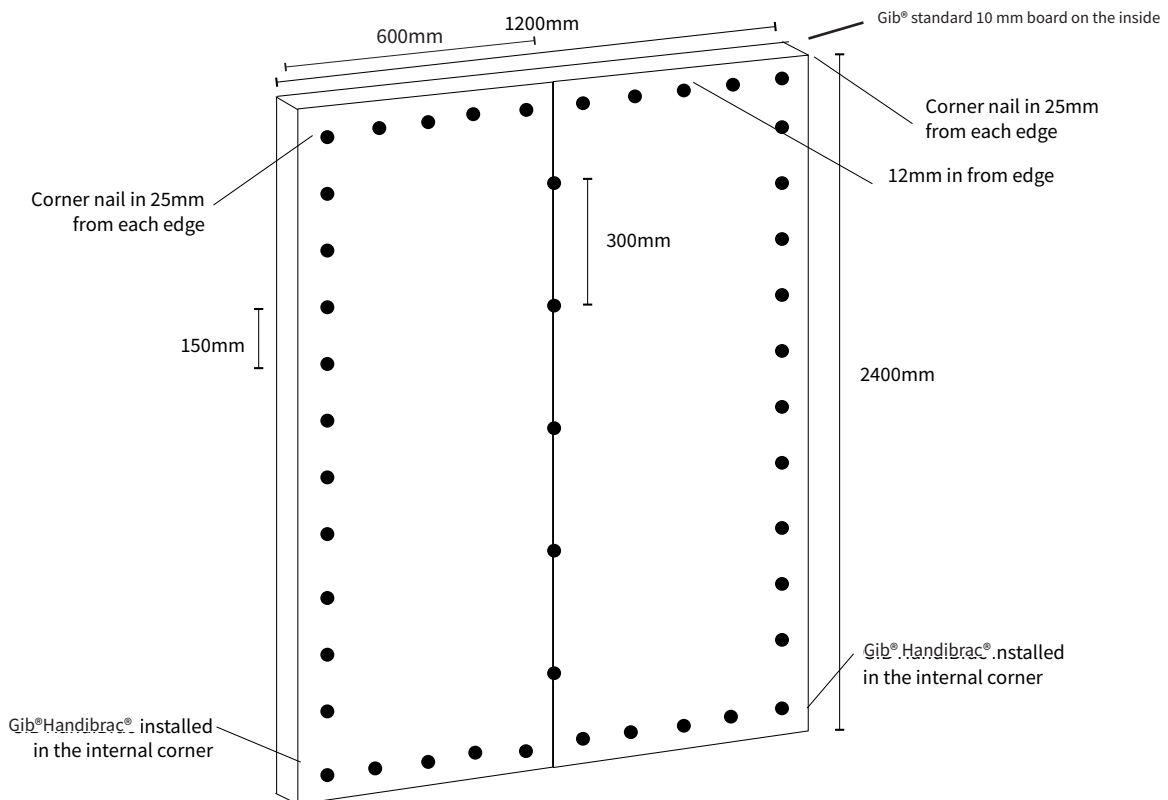

Note: Drawings are for illustration purposes only.

When Fixing with Nails

- 40x2.8mm hot-dipped galvanised fibre cement nails,
- Fixings to be at 150mm around the perimeter of the sheet
- Fixings to be at 300mm centres on the intermediate stud

When Fixing with Staples refer to page 32 figure 12 and below

- 1.6mm (16 gauge) 10.5mm crown, 35mm leg or longer, galvanised staples
 - Fixings to be 50mm, 100mm, 150mm maximum from each corner and then 150mm centres after that around the perimeter of the sheet
 - Must be no closer than 10mm from the edge of the sheet and no closer than 18mm from the top and bottom edges of the sheet.
 - Fixings to be at 300mm centres on the intermediate stud
 - Driven at right angles
 - 0.5mm depth only to allow for filling
- Fixing for Gib®
 - You can use the following screws for the Gib® side
 - 32mm 6g Gib® Grabber® High Thread Screws
 - 32mm 7g Gib® Grabber® Dual Thread Screws
 - 30mm Gib® Nails
 - Also use Gib® Fix Framing System or if fastening through Gib® Fix Angles use only 32mm or 7g Gib® Grabber® Dual Thread Screws

Fixings to be at 50mm, 100mm, 150mm maximum from each corner and then 150mm centres thereafter around the perimeter.

Fixings to be at 300mm on any intermediate studs for vertically placed sheets

For horizontally fixed sheets

 - Place single fasteners to the sheet where it crosses the stud
 - Use daubs of Gib® Fix adhesive at 300mm centres to intermediate studs

Place fasteners no closer than 12mm from the paper bound sheet edge and 18mm from any sheet end or cut edge
 - No fixing on nogs or dwangs required
 - Gib® Handibrac® hold down brackets fixed to each end-to-end studs and to the bottom

System IBS-PL-07

IBS PanelLine® 600mm x 2400mm on one side on a Steel Frame with Hold Downs

Wall construction:

- IBS PanelLine® fixed to one side
- Wall Framing to comply with NZBC B1 Structure
- NZBC B2 Durability
- Steel Framing to be in accordance with Nash Standard Part 2:May 2019 Light Steel Framed Buildings
- C Section studs shall have a minimum thickness of 0.75mm and a minimum nominal depth of 87mm with 35mm flanges
- Bottom Plate Fixing
 - Timber Floor
 - 50x50x3mm washer, fixed to timber floor framing using a 12mm x 100mm galvanised coach screw.
 - Concrete Floor
 - 50x50x3mm washer, fixed to the concrete slab using a proprietary concrete anchor with a minimum uplift capacity of 12kN taking into consideration concrete slab thickness (internal walls) and edge distance (external walls)
- Use self drilling screws with countersunk heads at least 25mm long and 6 or higher gauge. Must be galvanised or gold-passivated
- Fixings to be at 50mm, 100mm, 150mm from each corner and 150mm thereafter around the perimeter
- Fixings to be at 300mm centres on the intermediate studs
- No closer than 10mm from the edge of the sheet and no closer than 18mm from the top and bottom edges of the sheet
- Countersink to a depth of 0.5mm to allow for filling.

Figure 7

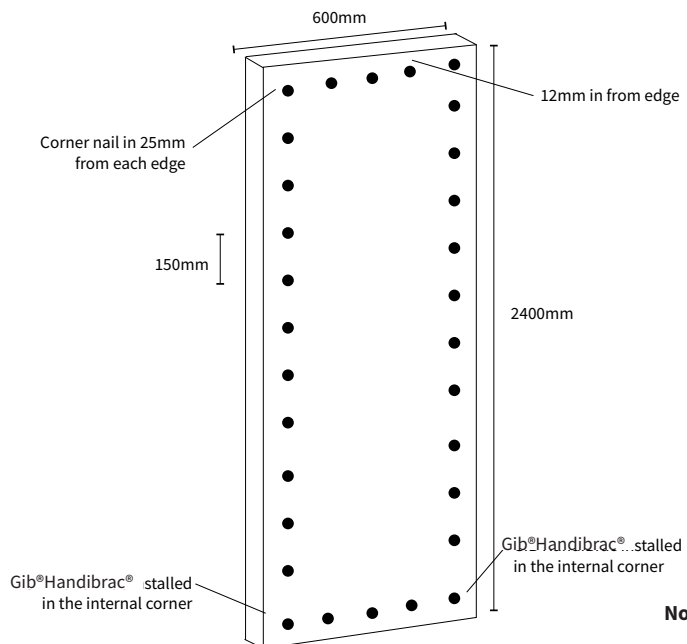

Note: Drawings are for illustration purposes only.

System IBS-PL-08

IBS PanelLine® 1200mm x 2400mm on one side on a Steel Frame with Hold Downs

Wall construction:

- IBS PanelLine® fixed to one side
- Wall Framing to comply with NZBC B1 Structure
- NZBC B2 Durability
- Steel Framing to be in accordance with Nash Standard Part 2:May 2019 Light Steel Framed Buildings
- C Section studs shall have a minimum thickness of 0.75mm and a minimum nominal depth of 87mm with 35mm flanges
- Bottom Plate Fixing
 - Timber Floor
 - 50x50x3mm washer, fixed to timber floor framing using a 12mm x 100mm galvanised coach screw.
 - Concrete Floor
 - 50x50x3mm washer, fixed to the concrete slab using a proprietary concrete anchor with a minimum uplift capacity of 12kN taking into consideration concrete slab thickness (internal walls) and edge distance (external walls)
- Use self drilling screws with countersunk heads at least 25mm long and 6 or higher gauge. Must be galvanised or gold-passivated
- Fixings to be at 50mm, 100mm, 150mm from each corner and 150mm thereafter around the perimeter
- Fixings to be at 300mm centres on the intermediate studs
- No closer than 10mm from the edge of the sheet and no closer than 18mm from the top and bottom edges of the sheet
- Countersink to a depth of 0.5mm to allow for filling.

Figure 8

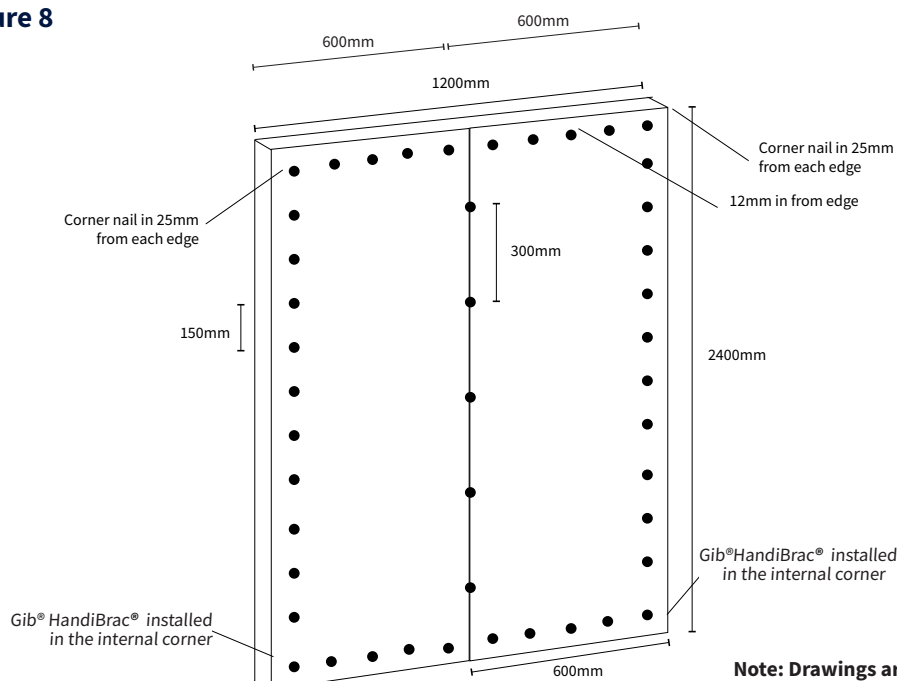

Note: Drawings are for illustration purposes only.

5. Installation

5.1 General Installation

Tools you will need

General carpentry and woodworking tools are all that you will need to install the panels. They can be cut with either a fine-tooth hand or power saw (we recommend using tungsten carbide blades) and cleaned up using a plane or sandpaper.

The panel edges can be easily hand-sanded with a flat block and 120-150-grit paper.

- Before you start make sure that the building is closed in and fully weather-tight.
- Any fixings must be no closer than 10mm from the edge of each panel and no closer than 18mm from the end of each panel.
- Always leave to acclimatise in the room for 48 hours to achieve equilibrium moisture content.
- If you are installing in a high humidity area then increase the expansion gaps to allow for movement of the sheets.

5.2 Installing as a bracing element

- IBS PanelLine® must be fixed vertically.
- Follow the hold-down systems as per Section 5.12 on page 32 - 35.
- Nails or screws at 150mm centres around the perimeter of each sheet and 300mm centres on the middle studs. No need for nails or screws on the nogs or dwangs.
- Ensure the nails or screws are fixed on the centre point of the studs.

5.3 Installing a wall bracing system

The top plates of all bracing panels must be connected at the joints with 3 kN or 6 kN top plate connectors, using 25 x 0.9 mm galvanized mild steel strap. For the 3 kN connectors, use 3 nails on each side of the joint, and for the 6 kN connectors, use 6 nails on each side.

Refer to the drawings on pages 32 - 35 to select the appropriate panel hold-down installation method.

5.4 Installing as a wall or ceiling lining

- IBS PanelLine® may be used as a ceiling lining in buildings designed in accordance with NZS 3604 provided it is installed with an appropriate mechanical fixing schedule and adequate framing support.
- Any penetration such as a fireplace flue penetration must comply with clearance requirements to combustible materials in accordance with AS/NZS 2918 and the flue manufacturer’s proprietary penetration system. Framing should be provided around the penetration to support all sheet edges.
- IBS PanelLine® may be fixed vertically or horizontally. When you install them horizontally check the grooves line up straight before installing.
- Leave a 5mm gap at the end of each ‘run’ or wall.
- If the wall length is more than 5 panels wide or 6m then leave an expansion joint of at least 3mm for each 6m length. This gap should be filled with a flexible sealant.
- You may nail or screw these sheets but for the best results we recommend panel adhesive and mechanical gun-driven pin method. This will mean that there is a little filling to be done prior to painting.

5.5 Lining timber framed walls

The panels must be supported by the timber framing. Refer to the table below for the required spacing.

Table 2 IBS PanelLine® Framework Support Centres		
Wall Lining		
Panel thickness (mm)	Stud centres (mm)	Nogging or dwang centres (mm)
9mm, 12mm	400	1200
	450	1200
	600	800

Table 3 IBS PanelLine® Timber Joists	
Ceiling Lining	
Joint/truss centres (mm)	Nogging or dwang centres (mm)
450	800
600	600
900	480
1200	480

5.6 Lining masonry walls

Masonry walls must be sealed from external moisture.

If installing panels on masonry walls below ground, long-term dampness may arise from construction moisture and hydrostatic pressure. We suggest the following extras:

- Install a full water proof membrane on the exterior of backfilled basement walls.
- Apply a moisture barrier (e.g., paint film) to basement walls, then install 40x25mm furring strips. See the Framing Support table for spacing and leave 25mm gaps at strip ends for air circulation.
- Install reflective foil insulation before attaching panels. Add small vent holes at the bottom of each panel, finished with facing plates.

5.7 Lining ceilings

For large rooms with breaking lines exceeding 5.0m, a ceiling diaphragm can be installed, provided each wall has at least 100 BU's.

If using panels to install a ceiling diaphragm, it must comply with NZS 3604, section 5.6.

Note: For ceiling lining for v-groove products. When installing this product horizontally on ceilings, please be aware that the alignment of the V-grooves may not line up perfectly between sheets. This is due to the way the product is manufactured with the groove pattern optimized for vertical (wall) installation, where consistent alignment is more critical and commonly expected. While this does not affect the structural integrity or performance of the panel, it may result in a visible offset when panels are butted together horizontally on ceilings. If precise groove alignment is essential for your design intent, we recommend reviewing panel layout prior to installation or considering an alternate orientation or panel size that better suits the visual outcome.

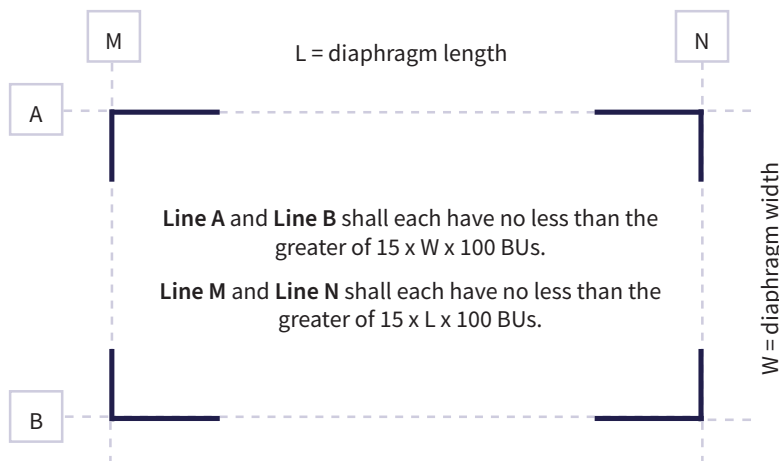

Note: Drawings are not to scale.

5.8 Steel Frame with Hold Downs

Wall Framing

Wall framing to comply with, NZBC B1 Structure, NZBC B2 Durability. Steel framing to be in accordance with NASH Standard Part Two: May 2019 Light Steel Framed Buildings. C section studs shall have a minimum thickness of 0.75mm and minimum nominal depth of 87mm with 35mm wide flanges.

Bottom Plate Fixing

Timber floor: 50 X 50 x 3mm washer, fixed to timber floor framing using a 12mm x 100mm galvanized coach screw.

Concrete floor: 50 X 50 x 3mm washer, fixed to the concrete slab using a proprietary concrete anchor with a minimum uplift capacity of 12kN taking into consideration concrete slab thickness (internal walls) and edge distance (external walls).

Wall Lining

- IBS PanelLine® Natural MDF sheets are fixed vertically.
- Sheets adjoining on the short edge require an approximate 2mm gap between them to allow for movement.
- Full sheets must be used wherever possible. Bracing panels must be fixed from top plate to bottom plate.

5.9 Sheet Fasteners

Self drilling screws with countersunk heads at least 25mm long and 6 or higher gauge. These should be galvanised or gold-passivated.

Fastening To Metal Studs

Clean the steel surface of any residual oil using a solvent on a rag to ensure proper adhesion. Apply panel adhesive to intermediate studs at a maximum of 300mm centres, avoiding application on sheet edges or under screws.

The sequence of attaching the IBS PanelLine® is important, as the face of the steel stud may initially deflect. Attach the first sheet to the open side of the stud, which may cause minor deflection, but it will pull tight against the sheet once the screw is fully tightened.

When fixing the second sheet, minimal deflection should occur, as the open flange is now supported by the previous sheet. Support the stud to prevent twisting.

Refer to figure 4 below.

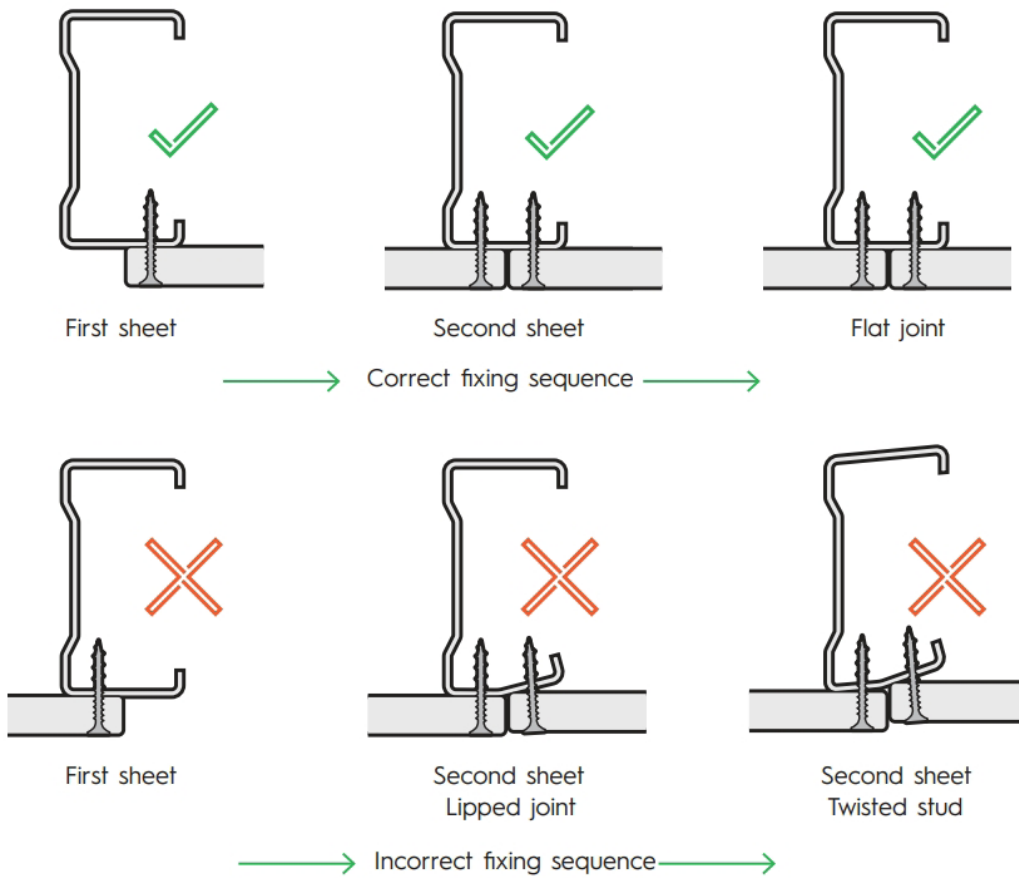

Figure 4
IBS-PL-06 Fastening to steel frame

5.10 Panel Hold-Downs

The IBS Panelline® Wall Bracing Systems are engineered to withstand earthquake and wind loads on timber frame buildings that are designed and constructed in compliance with NZS 3604: 2011. Additionally, they are suitable for light steel framed buildings that meet the requirements of NZBC B1 for structural integrity and B2 for durability.

IBS Panelline® Natural must be used when using IBS Panelline® as a bracing element.

Table 4 - IBS PanelLine® Brace MDF 2024 Bu/M Ratings							
System	Lining	Fixing	Width	BU/m Wind Wooden Floors	BU/M EQ Wooden Floors	BU/M Wind Concrete Floors	BU/M EQ Concrete Floors
IBS-PL-01 Timber Frame	9mm or 12mm PanellLine® one side with No Hold Down	Screws, clouts, staples	600mm	80	70	80	70
IBS-PL-02 Timber Frame	9mm or 12mm PanellLine® one side with Hold Down	Screws, clouts, staples	400mm	95	105	95	105
IBS-PL-03 Timber Frame	9mm or 12mm PanellLine® one side with Hold Down	Screws, clouts, staples	1200mm	120	120	140	130
IBS-PL-04 Timber Frame	9mm or 12mm PanellLine® one side with Hold Down	Finishing Nails	400mm	65	80	65	80
IBS-PL-05 Timber Frame	9mm or 12mm PanellLine® one side with Hold Down	Finishing Nails	1200mm	120	100	120	100
IBS-PL-06 Timber Frame	9mm or 12mm PanellLine® one side Gib® Standard 10mm other side with Hold Down	Screws, clouts, staples	1200mm	120	120	150	150
IBS-PL-07 Timber Frame	9mm or 12mm PanellLine® one side with Hold Down	Screws	600mm	85	90	85	90
IBS-PL-08 Timber Frame	9mm or 12mm PanellLine® one side with Hold Down	Screws	1200mm	100	95	100	95

Notes: These bracing ratings are quoted for wall heights of 2400 high. For calculations for different wall heights please refer to NZS 3604:2011 paragraph 8.3.1.4

5.11 IBS PanelLine® – Wall Bracing Systems

The bottom plate in bracing system IBS-PL-01 is fixed to the floor framing in accordance with NZS 3604: 2011 Table 8.19, which is either 2/100x3.75mm hand-driven nails or 3/90 x 3.15mm power-driven nails, at maximum 600mm centres.

Bracing systems IBS-PL-02, IBS-PL-03 or IBS-PL-04 require the use of end straps and a suitable hold-down anchor (see Figure 5) at each end of the bracing element.

Concrete floors

Internal walls – end straps

M12 galvanised bolt and 50x50x3mm square galvanised washer

6 - 30x2.5mm flat head nails to each side of stud

3 - 30x2.5mm flat head nails to each side of bottom plate (strap passes underneath plate)

400mm x 25mm x 0.9 galvanised bracing strap

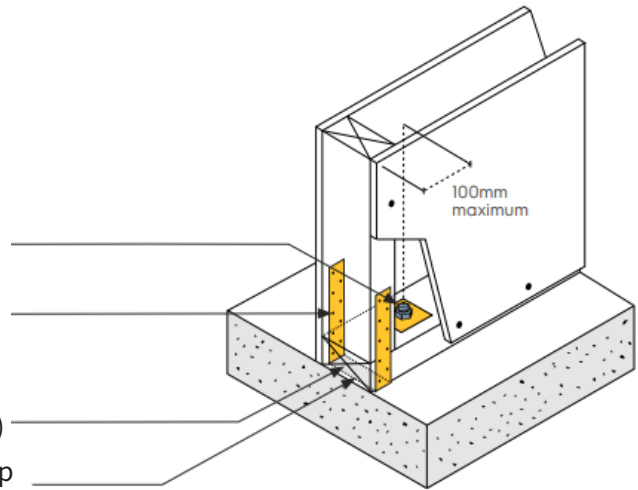

Figure 9

Concrete floors - Internal walls – end straps

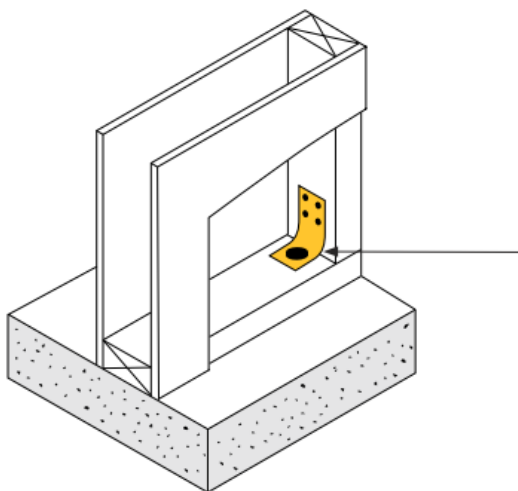

Figure10

Concrete floors - Internal walls – Gib® Handibrac®

Concrete floors

Internal walls – Gib® Handibrac® Locate the Gib® Handibrac® bracket centrally on the stud

Gib® Handibrac® bracket with concrete anchor with uplift capacity of at least 15kN

Alternatively the Gib® Handibrac® may be used instead of straps, but a suitable hold-down anchor with a characteristic or design strength of 12kN (for timber floors) and 15kN (for concrete floors) is required.

Within the length of the bracing element, intermediate fixings to the bottom plate are to be in accordance with NZS 3604.

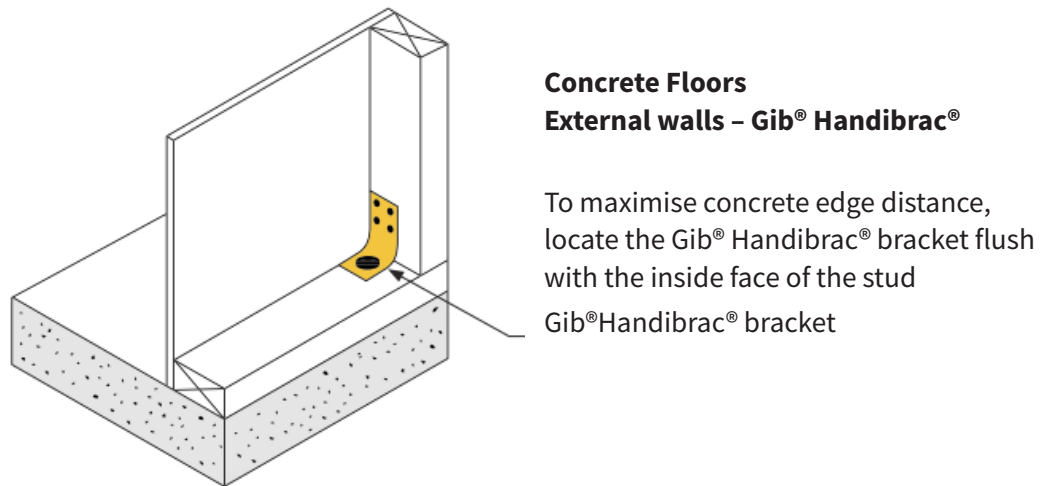

Figure 11
Concrete floors - External walls - Gib®Handibrac®

Timber floors
Internal walls – end straps

- 12mm dia x 150mm galvanised coach screw and 50x50x3mm square galvanised washer
- 6 - 30x2.5mm flat head nails to each side of stud
- 3 - 30x2.5mm flat head nails to each side of bottom plate (strap passes underneath plate)
- 400mm x 25mm x 0.9 galvanised bracing strap
- Screw centred over joist or bearer below or full depth solid block between bearers

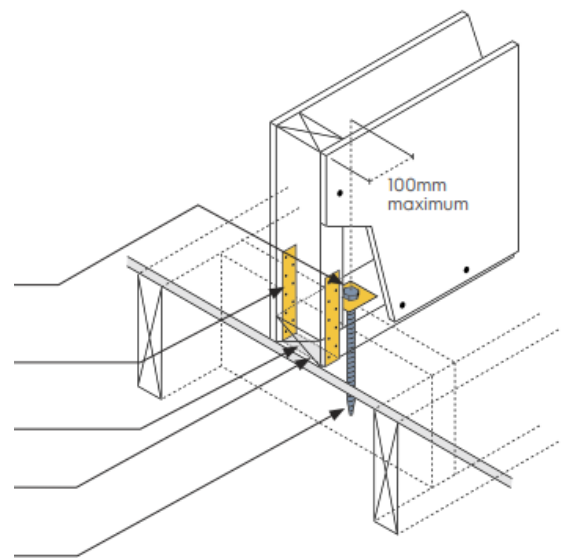

Figure 12
Timber floors - Internal walls - end straps

Timber floors

Internal walls – Gib® Handibrac®

Locate the Gib® Handibrac® bracket centrally on the stud and flush such that the coach screw is centred over the joist or bearer below or full depth solid block between bearers

Gib® Handibrac® bracket

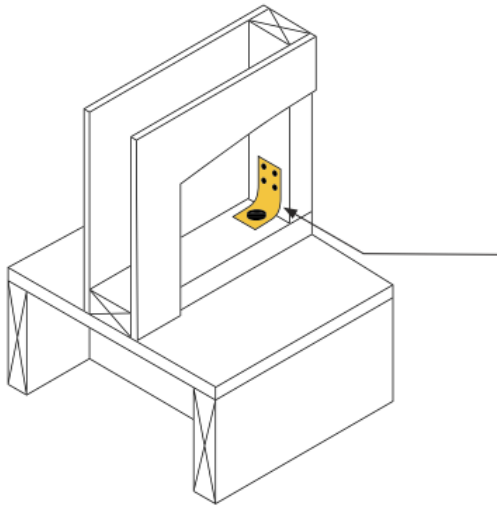

Figure 13

Timber floors - internal walls – Gib® HandiBrac®

Timber floors

External walls – Gib®Handibrac®

Locate the Gib® Handibrac® bracket flush such that the coach screw is centred over the joist or bearer below

Gib®Handibrac® bracket

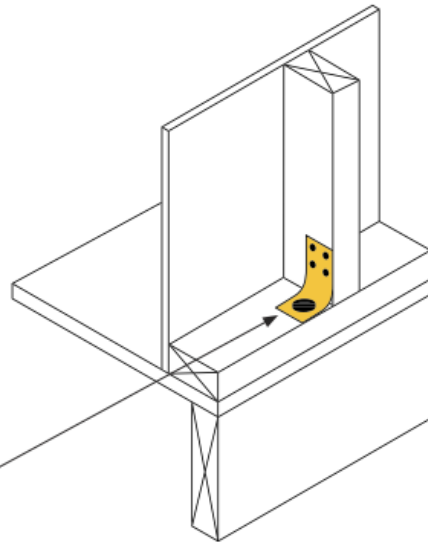

Figure 14

Timber floors - external walls –Gib® HandiBrac®

5.12 IBS PanelLine® Hold-Down Systems

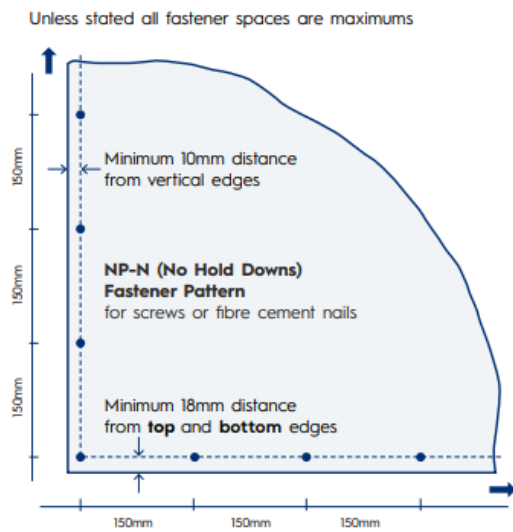

Figure 15
IBS-PL-01 (No Hold Downs) Fastener Pattern for Screws or Fibre Cement Nails

Staples Fastening Centres

50, 100, 150mm maximum from each corner and 150mm there after around the perimeter of the bracing element, 300mm centres on the intermediate stud.

Fixings must be no closer than 10mm from the sheet edge and no closer than 18mm from the top and bottom edges of the sheet.

Fixings are driven at right angles to the sheet. Driving pressure should be adjusted on the gun to allow crown penetration of approximately 0.5mm to allow for filling.

Fixing to dwangs/nogging is not required.

Screws Or Nails Fastening Centres

One in the corner then 150mm centres around the perimeter of the sheets and at 300mm centres to intermediate studs. Fixings must be no closer than 10mm from the sheet edge and no closer than 18mm from the top and bottom edges of the sheet.

Fixings are driven at right angles to the sheet until the head is flush with the sheet surface for nail fixings or countersunk approximately 0.5mm for screw fixings. Fixings must not be over-driven.

Fixing to dwangs/nogging is not required.

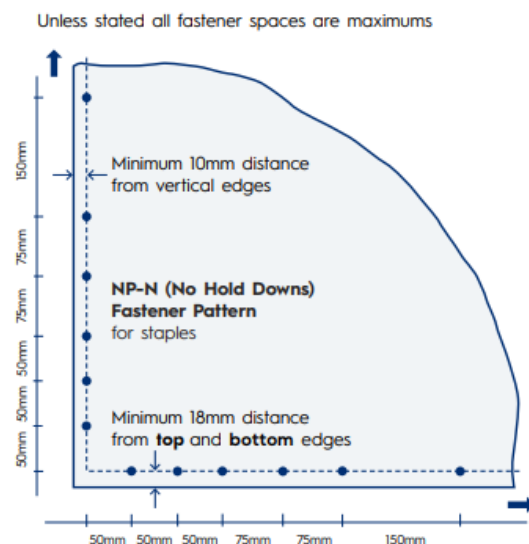

Figure 16 IBS-PL-01 (No Hold Downs) Fastener Pattern for Staples

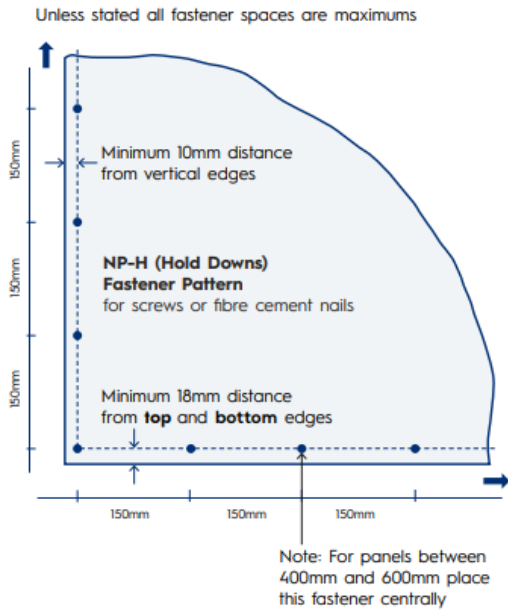

Figure 17
IBS-PL-02 (Hold Downs) Fastener Pattern for Screws or Fibre Cement Nails

Staples Fastening Centres

One in the corner then 150mm centres around the perimeter of the sheets and at 300mm centres to intermediate studs.

Fixings must be no closer than 10mm from the sheet edge and no closer than 18mm from the top and bottom edges of the sheet.

Fixings are driven at right angles to the sheet until the head is flush with the sheet surface for nail fixings or countersunk approximately 0.5mm for screw fixings. Fixings must not be over driven.

Fixing to dwangs/nogging is not required.

Screws Or Nails Fastening Centres

One in the corner then 150mm centres around the perimeter of the sheets and at 300mm centres to intermediate studs. Fixings must be no closer than 10mm from the sheet edge and no closer than 18mm from the top and bottom edges of the sheet.

Fixings are driven at right angles to the sheet until the head is flush with the sheet surface for nail fixings or countersunk approximately 0.5mm for screw fixings. Fixings must not be over-driven.

Fixing to dwangs/nogging is not required.

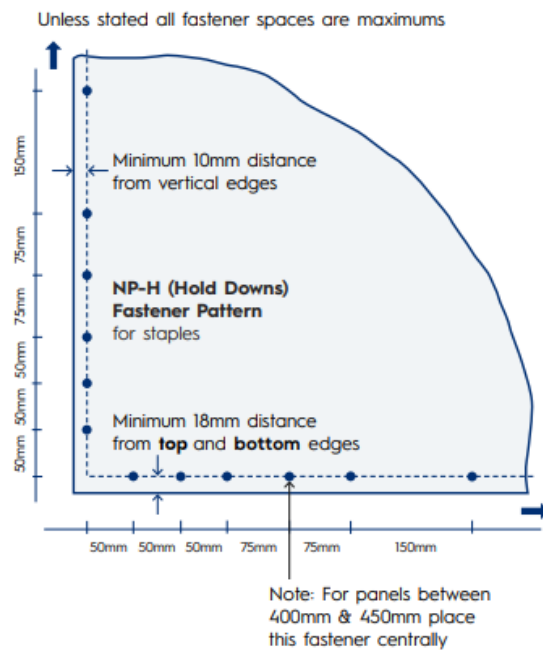

Figure 18
IBS-PL-02 (Hold Downs) Fastener Pattern for Staples

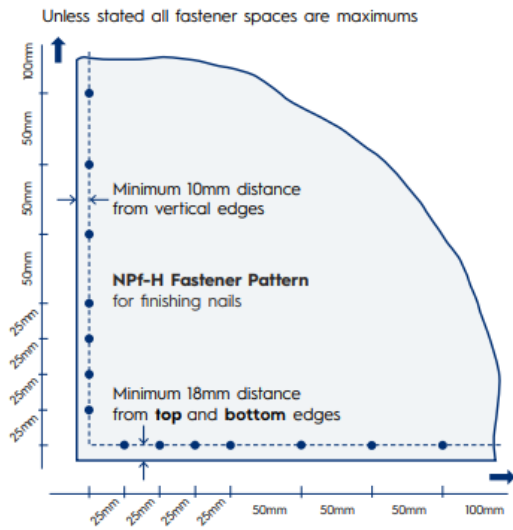

Figure 19
IBS-PL- 03 Fastener Pattern
for Finishing Nails

Gib® Fastener Centres

Gib® plasterboard side: 50, 100, 150mm maximum from each corner and 150mm thereafter around the perimeter of the bracing element. For vertically fixed sheets place fasteners at 300mm maximum centres to the intermediate sheet joints.

For horizontally fixed sheets place single fasteners to the sheet edge where it crosses the stud. Use daubs of Gib®Fix® adhesive at 300mm maximum centres to intermediate studs. Place fasteners no closer than 12mm from paper bound sheet edges and 18mm from any sheet end or cut edge.

Nails Fastening Centres

25, 50, 75, 100, 150mm from each corner and 100mm centres thereafter around the perimeter. 150mm centres on the intermediate stud.

Fixings must be no closer than 10mm from the sheet edge and no closer than 18mm from the top and bottom edges of the sheet. Fixings are driven at right angles to the sheet. Driving pressure should be adjusted on the gun to allow nail head penetration of approximately 0.5mm to allow for filling.

Fixing to dwangs/nogging is not required.

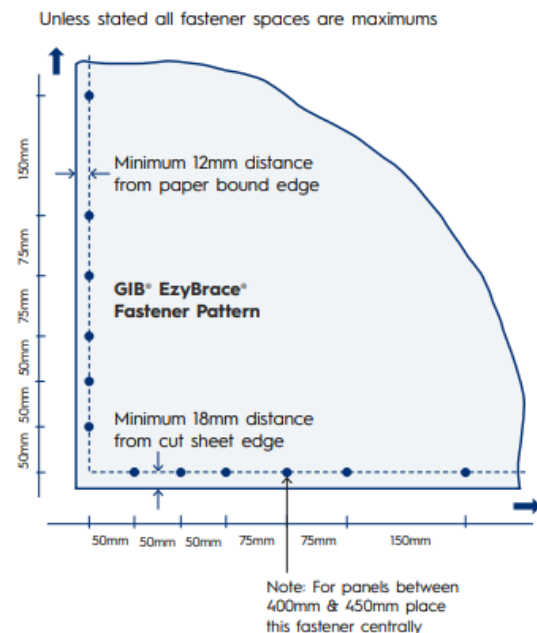
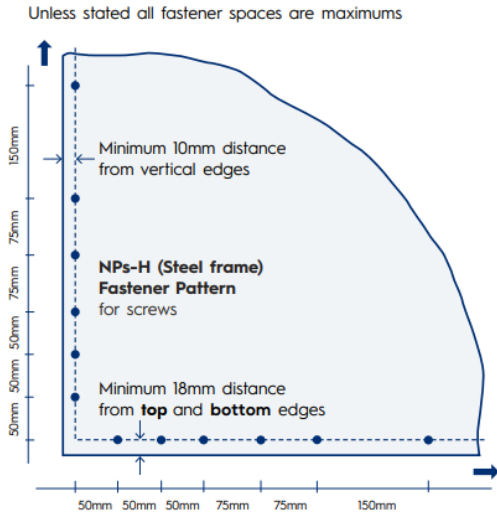

Figure 20
IBS-PL-04 Fastener Pattern



Screw Fastening Centres

50, 100, 150mm from each corner and 150mm centres thereafter around the perimeter. 300 centres on the intermediate stud.

Fixings must be no closer than 10mm from the sheet edge and no closer than 18mm from the top and bottom edges of the sheet. Fixings are driven at right angles to the sheet and countersunk approximately 0.5mm.

Figure 21
IBS-PL-06 (Steel Frame)
Fastener Pattern for Screws

Jointing

Joint strength is important in delivering bracing system performance. All fastener heads stopped and all sheet joints Gib® Joint Tape reinforced and stopped in accordance with the Gib® Site Guide.

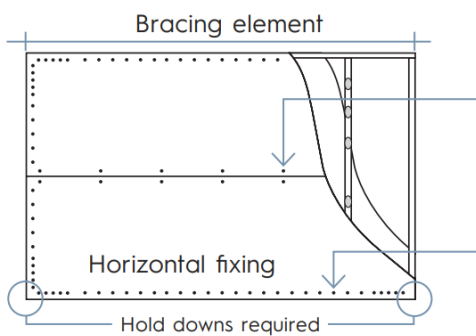

Single 32mm x 6g Gib® Grabber® High Thread Screws, 32mm x 7g Gib® Grabber® Dual Thread Screws or 30mm Gib® Nails where sheets cross studs

32mm x 6g Gib® Grabber® High Thread Screws only, 32mm x 7g Gib® Grabber® Dual Thread Screws or 30mm Gib® Nails

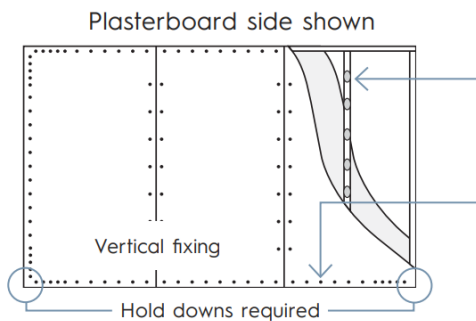

Daub of Gib®Fix® adhesive at 300mm centres to intermediate studs and nogs

Single 32mm x 6g Gib® Grabber® High Thread Screws, 32mm x 7g Gib® Grabber® Dual Thread Screws or 30mm Gib® Nails at 300mm centres.

6. Finishing

6.1 Preparation

Use in dry, internal, thermally insulated locations with moisture content of supporting timber framing not exceeding 18%. The system must be exposed or easily accessible for inspection and should not be placed in high moisture areas (e.g., bathrooms, toilets, kitchens). Ensure the building is closed in and weathertight before installation.

Once installed, IBS PanelLine® should not be left in its raw state.

6.2 Sealants

All sealants must meet the relevant requirements of the NZBC. Their application usage must be in accordance with manufacturer's instructions. Check with sealant manufacturer prior to coating over sealants. Some sealant manufacturers do not recommend coating over their product.

6.3 Coating

For installations where IBS Natural PanelLine® has been used follow these Steps:

Preparation:

- Ensure the surface is clean and free from dust, dirt, and grease. Wipe down the IBS PanelLine® with a damp cloth and let it dry completely.

1. Filling Holes:

- Use a suitable wood filler to fill any holes or imperfections on the IBS PanelLine®. Apply the filler with a putty knife, pressing it firmly into the holes.
- Allow the filler to dry according to the manufacturer's instructions.

2. Sanding:

- Once the filler is dry, sand the filled areas with fine-grit sandpaper (e.g., 120-150 grit) until smooth and level with the surrounding surface.
- Sand the entire surface of the IBS PanelLine® lightly with a 240 or 320 grit paper to ensure good adhesion of the undercoat. Wipe away any dust with a clean, dry cloth.

3. Applying Undercoat:

- Apply one coat of a suitable undercoat to the IBS PanelLine® using a brush or roller. Ensure even coverage and smooth application. Make sure that you have suitable coverage in the V-Groove with the undercoat.
- Allow the undercoat to dry completely as per the manufacturer's instructions.

4. Sanding After Undercoat:

- Lightly sand the undercoated surface with fine-grit sandpaper (e.g., 220 grit) to remove any brush marks or imperfections. Wipe away the dust with a clean, dry cloth.

5. Applying First Top Coat:

- Apply the first top coat of paint to the IBS PanelLine® using a brush or roller. Ensure even coverage and smooth application.
- Allow the first top coat to dry completely according to the manufacturer's instructions.

6. Sanding Between Coats:

- Lightly sand the first top coat with fine-grit sandpaper (e.g., 220 grit) to ensure a smooth finish. Wipe away any dust with a clean, dry cloth.

7. Applying Second Top Coat:

- Apply the second top coat of paint to the IBS PanelLine® using a brush or roller. Ensure even coverage and a smooth finish.
- Allow the second top coat to dry completely as per the manufacturer's instructions.

Final Touches

- Inspect the painted surface for any imperfections and touch up if necessary.
- Clean your brushes and rollers according to the paint manufacturer's recommendations.

By following these steps, you can achieve a professional and durable finish on your IBS PanelLine®. If you have any further questions or need additional assistance, feel free to ask!

For installations where IBS PanelLine® **Pre-Primed** has been used follow these Steps:

1. Preparation:

- Ensure the pre-primed IBS PanelLine® is clean and free from dust, dirt, and grease. Wipe down the surface with a damp cloth and let it dry completely.

2. Filling Holes:

- Use a suitable wood filler to fill any holes or imperfections on the IBS PanelLine®. Apply the filler with a putty knife, pressing it firmly into the holes. Allow the filler to dry according to the manufacturer's instructions.

3. Sanding:

- Once the filler is dry, sand the filled areas with fine-grit sandpaper (e.g., 120-150 grit) until smooth and level with the surrounding surface. Lightly sand the entire pre-primed surface with a 240 or 320 grit sandpaper to ensure good adhesion of the primer and top coats. Wipe away any dust with a clean, dry cloth.

4. Applying Primer on Filled Areas:

- Apply a coat of primer to the areas where filler was used. This ensures that the filled areas are sealed and ready for painting. Allow the primer to dry completely as per the manufacturer's instructions.

5. Sanding After Primer:

- Lightly sand the primed areas with fine-grit sandpaper (e.g., 220 grit) to ensure a smooth finish. Wipe away any dust with a clean, dry cloth.

6. Applying First Top Coat:

- Apply the first top coat of paint to the IBS PanelLine® using a brush or roller. Ensure even coverage and smooth application. Allow the first top coat to dry completely according to the manufacturer's instructions.

7. Sanding Between Coats:

- Lightly sand the first top coat with fine-grit sandpaper (e.g., 220 grit) to ensure a smooth finish. Wipe away any dust with a clean, dry cloth.

8. Applying Second Top Coat:

- Apply the second top coat of paint to the IBS PanelLine® using a brush or roller. Ensure even coverage and a smooth finish. Allow the second top coat to dry completely as per the manufacturer's instructions.

Final Touches

- Inspect the painted surface for any imperfections and touch up if necessary. Clean your brushes and rollers according to the paint manufacturer's recommendations.

By following these steps, you can achieve a professional and durable finish on your pre-primed IBS PanelLine®. If you have any further questions or need additional assistance, feel free to ask!

7. Care & Maintenance

7.1 Care & Maintenance

To ensure the longevity and performance of IBS PanelLine®, it is essential to keep the product clean and dry. Regular maintenance involves wiping down the surface regularly to remove any accumulated dust or dirt and avoiding exposure to moisture. In the event that the panels do become wet, they should be allowed to dry thoroughly. If the panels do not return to their original state after drying, replacement may be necessary to maintain their structural integrity.

It is also important to maintain the integrity of the paint system applied to the panels. Regularly inspect the painted surface for any signs of wear, damage, or deterioration. Promptly touch up any affected areas to prevent exposure of the underlying material, which can lead to further degradation and compromise the durability of the panels.

In situations where IBS PanelLine® has been used as a bracing element and it becomes wet, immediate replacement of the affected sheet is recommended. When installing the new sheet, it is critical to follow the original system's specifications, including the correct placement and type of fixings. This ensures that the structural stability and safety of the building are preserved.

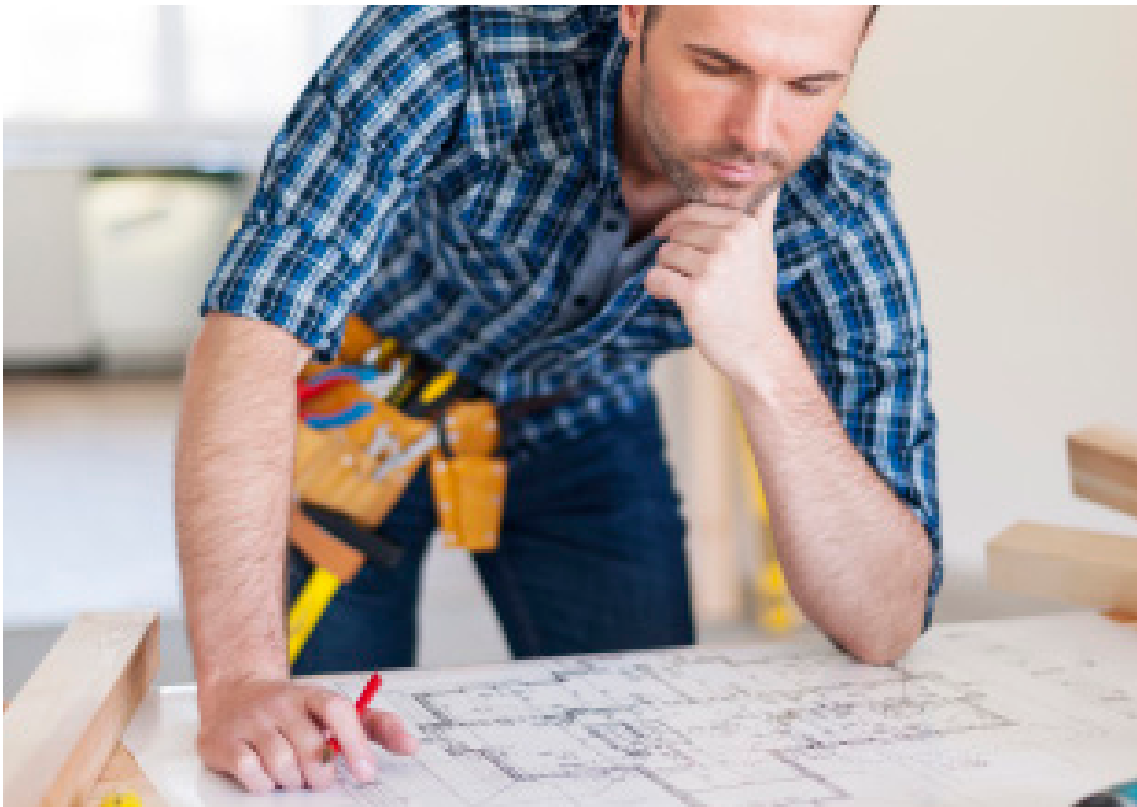

8. Warranty

8.1 Warranty

Independent Building Supplies Limited (IBS) supplies sustainable building products, which when used and installed in accordance with all relevant instructions and specifications, will be fit for purpose.

As part of our commitment to performance, IBS provides a warranty in respect of IBS PanelLine® (Product) in accordance with the following terms and conditions.

These terms and conditions must be read in conjunction with all product specific relevant and applicable technical documentation, information and guidelines published or referenced by IBS from time to time (Specifications) in relation to the Product.

1. IBS warrants that:

- 1.1 At the time of delivery to the merchant or site (where applicable) the IBS supplied Product will:
 - (a) be free from freight related defects;
 - (b) be free from defects that may have arisen through defective factory workmanship or materials; and
 - (c) conform to the performance characteristics listed on the applicable pass™ (warranted condition).
- 1.2 Once installed properly and in accordance with all appropriate Specifications the Product will continue to meet the relevant provisions of the building code as described on the applicable pass™ (warranted performance).

2. Date warranty valid:

- 2.1 IBS warrants:
 - (a) the warranted performance for 5 years from proven date of purchase or dispatch from IBS whichever date is the earlier; and
 - (b) the warranted performance for the durability period as specified by the NZ Building Code.

The durability period begins from the date the product is first installed or two months after the date of delivery, whichever is the earlier.

- 2.2 All enquiries relating to this warranty must (in the first instance) be directed to the place of purchase, the supplier or the installer.
- 2.3 By submitting a claim under the warranty, you grant IBS and its agents, consultants and contractors full rights of access, at no cost and at any reasonable time, to the relevant building to inspect the Product and the installation method for the purpose of determining the validity of the claim.

3. In the event a breach of the warranty is proven, the following applies:

- 3.1 For any valid and accepted breach of a warranty, IBS will, in its sole discretion, either:
 - (a) repair, replace or rectify the defective Product; or
 - (b) refund the purchase price of the defective Product. Where applicable the value will be reduced pro-rata, based on the remaining life of the Product (as set by the relevant durability requirements of the NZ Building Code).
- 3.2 Any action taken by IBS in satisfaction of a warranty claim shall constitute full and final settlement of all claims and IBS's total liability related to a breach of the warranty is limited to the direct cost to IBS of performing either of the above options.
- 3.3 IBS reserves the right to supply other comparable materials or products should the warranted Product no longer be supplied by IBS.

4. This warranty is subject to the following:

- 4.1 Receipt of evidence of the date of purchase of the Product.
- 4.2 Evidence satisfactory to IBS of failure of the Product.
- 4.3 Receipt of a written claim from the claimant either within 30 days of when the defect or failure of the Product would have become reasonably apparent or, if the defect was reasonably apparent prior to installation, then the claim must be made prior to installation.
- 4.4 The claim must include full details of the alleged defect in the Product.

- 4.5 Evidence satisfactory to IBS that all design, storage, transport, installation and maintenance requirements for the Product have been met or carried out in accordance with the Specifications and in terms of best building practice and the building code.
- 4.6 The warranty does not cover failure or problems caused by defective use, failure relating to improper design of the project structure, structural failure, settlement, movement of materials to which the Product is attached or dependent on, acts of God including but not limited to earthquakes, cyclones, floods or other severe weather conditions, inadequate maintenance, growth of mould, mildew, fungi, bacteria or any organism on any Product , or acts or omissions of a third party over whom IBS has no control.
- 4.7 The warranty does not cover failure or loss arising from the failure to follow all relevant IBS advice and requirements or failure to adhere to the Specifications.
- 4.8 Normal wear and tear, including non- performance related changes, are excluded from this warranty.
- 4.9 All relevant information relating to the Specifications is uncontrolled in printed format and is available from IBS (refer to www.ibs.co.nz).

5. Limitations

- 5.1 IBS will not be liable for a warranty claim unless:
 - (a) the use of the Product meets the installation, storage, transport, use and maintenance requirements and Specifications in respect of the Product and the customer is responsible to ensure these are received and understood;
 - and (b) the claim procedure set out in these terms is correctly followed and the required information is provided.

- 5.2 IBS will in no circumstances be liable for:
- (a) any damage or loss caused by a person other than IBS, or by any other factor outside IBS's reasonable control, including without limitation fire, moisture, lightning, liquid, strike or lockout, chemicals, insects or animal;
 - (b) any damage or loss caused or contributed to by incorrect or improper use or a failure to comply with all Specifications and all applicable building codes, regulations and legislation;
 - (c) neglect, abuse, misuse, growth of mould/ mildew/fungi/bacteria or other organism; or
 - (d) any direct or indirect loss, or consequential loss or damage, of any kind.
- 5.3 All warranties, conditions, liabilities and obligations implied by law or custom (other than the warranties in these terms) are excluded to the fullest extent permitted by law, and without limitation, where the Product is provided for the purposes of trade, the provisions of the Consumer Guarantees Act 1993 shall not apply.
- 5.4 Except as provided in these terms, IBS will not be liable (under legislation, contract, tort, or otherwise including in equity) in respect of any defects in the Product or for any other cost, expense or liability caused by or related to the use of the Product.

9. Technical Properties

9.1 Technical Properties

IBS PanelLine® Brace is more impact resistant than other wall lining options and makes a great Dado Line or full length sheet.

The choice of underlay and lining of exterior wall siding, interior wall lining, ceiling and partition system.

Table 6 - IBS PanelLine® Technical Properties			
	Property	Metric	Value
1	Density	Kg/m ³	730
2	Weight	Kg/m ²	6.6
3	Internal Bond	kPa	920
4	Moisture Content	%	7.5
5	Thickness Swell 24h	%	11.4
6	MoE	MPa	3300
7	MoR	MPa	40
8	Length/Width Tolerance	mm	+/-2.0
9	Thickness Tolerance	mm	+/-0.15
10	Straightness	mm	1.5
11	Squareness	mm	3.0

10. Additional Resources

10.1 Compliance and Information

For compliance & information of IBS PanelLine® refer to:

- IBS Product Specification
- IBS Maintenance and Warranty of IBS PanelLine®
- www.ibs.co.nz
- 0800 367 759

10.2 Designing outside of scope

If you're designing or installing a product that deviates from these specifications or the guidelines in this design and install guide, please note that this will void any warranty claims unless specifically approved by IBS prior to any works starting.



11. Frequently Asked Questions

Q. What are the recommended safety precautions when installing IBS PanelLine® sheets?

- A. Ensure to work in a well-ventilated area, use dust masks and eye protection when cutting or sanding the sheets. Follow all safety guidelines provided in the technical literature.

Q. How should IBS PanelLine® sheets be stored prior to installation?

- A. Store the sheets flat and off the ground in a dry, covered area to prevent warping and damage.

Q. What tools and materials are required for the installation of IBS PanelLine® sheets?

- A. You will need standard carpentry tools, including a high-speed cutting tool, drill, screws or nails, tape measure, level, and appropriate personal protective equipment.

Q. Can IBS PanelLine® sheets be painted, and if so, what type of paint should be used?

- A. Yes, IBS PanelLine® sheets can be painted. Use a high-quality, polyurethane paint suitable for MDF materials. We recommend using three coats: a primer and two top coats.

Q. What are the guidelines for cutting and drilling IBS PanelLine® sheets to ensure durability?

- A. Use a carbide-tipped blade for cutting and pre-drill holes for fasteners to prevent cracking. Follow the manufacturer's guidelines for specific cutting and drilling instructions.

Q. How do you ensure proper alignment and spacing when installing IBS PanelLine® sheets?

- A. Use a chalk line or laser level to mark guidelines on the substrate. Maintain the recommended gap between sheets for expansion and contraction, as specified in the installation guide.

Q. Are there any specific environmental conditions to consider when installing IBS PanelLine® sheets?

- A. Consider the local climate, such as humidity and temperature, and follow the manufacturer's guidelines for installation in various environmental conditions.

Q. How do you handle and dispose of waste materials during the installation of IBS PanelLine® sheets?

- A. Collect offcuts and dust in a designated area and dispose of them according to local regulations. Avoid creating dust and dispose of waste responsibly .

Q. What maintenance is required after the installation of IBS PanelLine® sheets to ensure longevity?

- A. Regularly inspect the sheets for any signs of damage or wear. Clean the surface with mild soap and water, and touch up paint as needed to maintain the protective coating.

12. Limitations

When you are specifying and installing IBS PanelLine®, the IBS PanelLine® Installation Guide must be followed.

- IBS PanelLine® should not be installed on timber framing where the moisture content is greater than 18%.
- IBS PanelLine® Brace is not recommended for use in areas with high moisture or water exposure, such as kitchens, bathrooms, toilets, or laundries.
- The minimum framing dimensions must be 90 x 45 mm for external walls and 75 x 45 mm for nonstructural internal walls.
- Do not expose the sheets to temperatures of 50°C or greater for prolonged periods.

These considerations are critical to the successful installation of IBS PanelLine®. Using this sheet as a checklist during installation will aid in problem free product installation and long term product durability post construction.

IMPORTANT NOTES:

All sections of this checklist should be completed in full.

Careful adherence to technical specification literature is critically important for completing IBS PanelLine® construction. The construction shall comply with requirements of building consent. Any variations made should be approved by the BCA prior to work being undertaken.



13. Installation checklist

Items to be checked		✓ Tick <input type="checkbox"/>	Notes
1. Pre-Installation Checks			
1	Confirm intended use is dry interior only (not for wet or exterior environments)	<input type="checkbox"/>	
2	Ensure timber framing moisture content is ≤ 18%	<input type="checkbox"/>	
3	Verify framing is rigid and compliant with NZS 3604 or NASH Design (for steel)	<input type="checkbox"/>	
2. Fixing Fastening			
4	Use approved fixings and follow spacing guidelines from the installation guide	<input type="checkbox"/>	
5	Fix panels directly to framing or approved substrates only	<input type="checkbox"/>	
6	Avoid unsupported installations or non-compliant framing systems	<input type="checkbox"/>	
3. Environmental & Safety Requirements			
7	Work in a well-ventilated area	<input type="checkbox"/>	
8	Use dust extraction tools or wear a P2 dust mask, goggles, and protective clothing	<input type="checkbox"/>	
9	Dispose of offcuts and dust in accordance with local waste authority regulations	<input type="checkbox"/>	

Installation checklist

Items to be checked		✓ Tick <input type="checkbox"/>	Notes
4. Framing			
10	External wall timber framing is treated to min H1.2 treatment levels. Specify if any other treatment to be used.	<input type="checkbox"/>	
11	Timber framing set out, i.e. Nog or Stud spacing or dwang spacing.	<input type="checkbox"/>	
12	Timber frame moisture content must be as per NZS 3602 at the time of fixing the IBS Panelline® Sheet.	<input type="checkbox"/>	
13	Framing straightness. Nogs flush with studs, and studs flush with top and bottom plates.	<input type="checkbox"/>	

5. Sheet fixing and set out			
14	Sheet fixing carried out as per IBS Panelline® Sheet technical specification literature.	<input type="checkbox"/>	
15	IBS Panelline® Natural MDF must be kept away from heat sources like stoves, heaters, and chimneys in accordance with AS/NZS 2918	<input type="checkbox"/>	



IBS PanelLine®

Design & Installation Guide

June 2026



Scan the QR code to view
all IBS PanelLine® documents.

3 Zelian Drive, East Tamaki
Auckland, New Zealand 2013

General Inquiries:

☎ 0800 367 759

✉ info@ibs.co.nz

🌐 www.ibs.co.nz