

IBS RigidRAP®

Design & Installation Guide

April 2024



BUILDING BETTER HOMES

**Proudly Kiwi Owned and
Operated for over 30 years**



Contents

1. Introduction

1.1	What is IBS RigidRAP®?	4
1.2	What is a Rigid Air Barrier?	4
1.3	Benefits of IBS RigidRAP®	4
1.4	IBS RigidRAP® Intended Use	5
1.5	Supporting Information	5

2. Best Practice

2.1	Designer/Installer Skill Level	6
2.2	Health and Safety	6
2.3	Sawing, Drilling, Shaping	6
2.4	Handling and Storage	7
2.5	Finishing	7
2.6	Quality Assurance	7

3. External Wall Bracing

3.1	Scope of Use	8
3.2	Limitations	8
3.3	IBS RigidRAP® Wall Bracing System	9
3.4	Bracing on Timber and Concrete floors	10
3.5	Vertical and Horizontal Joints	10
3.6	Bracing Fastening	10
3.7	IBS RigidRAP® Bracing Capacity (Table 1)	11
3.8	IBS RigidRAP® - XT Bracing Capacity (Table 2) (Timber Frames)	21
3.9	Top Plate to Rafter or Truss Connections	28
3.10	Lintel Tie Down Details	29
3.11	Fixings - RigidRAP®	30
3.12	Fixings - RigidRAP® - XT (Timber Frames)	30
3.13	Mechanical Connections	31
3.14	Bottom Plate Fixing Details	32
3.15	Hold Down Details	33

4.	Joint / Window Sealing & Penetrations	
4.1	Recommended Tape Options	34
4.2	Installing Service Penetration	35
4.3	Installing Window Opening	35
5.	External Wall Wrap - Rigid Air Barrier	
5.1	Scope of Use	36
5.2	Non-Structural Rigid Air Barrier	36
6.	Temporary Weather Cladding	
6.1	Scope of Use	37
7.	Further Information	
7.1	What is OSB3?	37
7.2	What is wall underlay?	37
7.3	IBS RigidRAP® CodeMark explained	37
8.	Additional Resources	
8.1	Compliance and Information	38
8.2	Available Details	38
9.	Limitations	39
10.	Frequently Asked Questions	40
11.	Installation Check List	41

NZBN 9429000097253

IBS RigidRAP® Product Details			
L x W x Thickness (mm)	Weight (kg)	IBS Product Code	GTIN
2440 x 1196 x 8	16	RRAP082412	09421028769716
2745 x 1196 x 8	18	RRAP082712	09421028769723
3050 x 1196 x 8	21	RRAP083012	09421028769730

Contact us for more information or to talk to our team.

www.ibs.co.nz | 0800 367 759 | info@ibs.co.nz

1. Introduction

This document is intended for designers and installers to ensure that IBS RigidRAP® (Rigid Air Barrier) is specified and installed correctly.

1.1 What is IBS RigidRAP®?

IBS RigidRAP® is an 8mm OSB3 (Oriented Strand Board) which has been manufactured specifically for New Zealand, for use as a bracing element and/or rigid air barrier. IBS RigidRAP® is a dual layer rigid air barrier system available in New Zealand that comes laminated with an approved building paper to the board.

Your house gets dual protection from the weather during your building process and replaces traditional building wrap. When compared to similar products it is more cost effective, easy to install, lightweight and makes your house warmer, stronger and quieter.

As an OSB3 panel manufactured in accordance with EN13986:2004, it is suitable for use in humid conditions where the panel in-service moisture content does not exceed 18%. Compliance with the NZ Building Code (NZBC) is established through product certification (CodeMark). IBS RigidRAP® meets all the requirements of Table 23 (clause E2 - external moisture) from the compliance document for the NZ Building Code.

1.2 What is a Rigid Air Barrier?

A rigid air barrier is an underlay which acts as a barrier against air pressure and water infiltration from the outside to the inside of the building. They are easy to install, durable and is a solid substrate for the installation of flashing tape to window and door openings and exterior penetrations.

1.3 Benefits of IBS RigidRAP®

As designers, builders and homeowners move towards more sustainable and durable materials and systems, the benefits of IBS RigidRAP® are becoming more relevant.

Key Attributes and Benefits

- Reduces building time
- Lightweight material, simple and easy to install
- Provides rapid moisture protection of the building
- Allows for interior construction to continue
- Provides a greater level of site security
- Reduces structural timber movement
- Provides a rigid structure
- Provides weather tightness for the building.

1.4 IBS RigidRAP® Intended Use

Intended use for IBS RigidRAP® are:

1. External wall bracing
2. External wall wrap - rigid air barrier
3. Temporary weather cladding (up to 90 days)

Read the following sections for more information on each intended use.

1.5 Supporting Information

This document must be read in conjunction with the:

- IBS Product Specification for IBS RigidRAP®
- IBS Maintenance and Warranty for IBS RigidRAP®

CAD details and all other information including any updates are available at www.ibs.co.nz.



2. Best Practice

2.1 Designer/Installer Skill Level

Where IBS RigidRAP® is specified and/or installed, the designer/installer shall have the appropriate skills and knowledge of the product and access to all IBS RigidRAP® technical information.

Visit www.ibs.co.nz for more information.

2.2 Health and Safety

When installing IBS RigidRAP® take all steps to ensure your safety and the safety of others;

- Ensure that when cutting or drilling IBS RigidRAP® that there is adequate ventilation or mechanical dust extraction
- Ensure IBS RigidRAP® is well supported when cutting or drilling the panel
- Appropriate close fit clothing shall be worn at all times
- Wear eye, ear and footwear protection when working with IBS RigidRAP®.

Site considerations:

- Selection of the right equipment for working from a height
- Safe working with ladders and stepladders
- Maintain a clear unobstructed work area.

For further information, refer to:

- The Absolutely Essential Health and Safety Toolkit
- Worksafe New Zealand Quick Guide.

2.3 Sawing, Drilling, Shaping

IBS RigidRAP® panels may be sawn and shaped in the same way as solid wood, although carbide tipped cutters are recommended.

If panels are to be installed in a visible location, ensure clean-cut edges with sharp tools, using a backing block to minimize break out. The feed rate shall be slower than for solid wood.

2.4 Handling and Storage

Storage and handling in transport is essential for the protection of IBS RigidRAP®. The following simple principles shall be considered:

- Strapping and shrink wrap shall be removed immediately upon arrival at the installer's storage area or on site.
- IBS RigidRAP® shall be laid flat on timber bearers. The spacing between the timber shall be no more than 800mm.
- Ensure the storage bearers are in true alignment if several pallets are stacked on top of each other.
- When stored outside, ensure there is sufficient clearance between the ground and IBS RigidRAP® to prevent moisture transfer and allow air circulation. Cover with a waterproof tarpaulin.
- IBS RigidRAP® must not be exposed to the weather for more than 90 days.
- When manually handling IBS RigidRAP® ensure the panels are lifted in the central third.
- IBS RigidRAP® shall be allowed to acclimatise to the site conditions for 48 hours prior to installation.

IBS RigidRAP® shall not be exposed to the weather or ultraviolet light for more than 90 days during construction.

2.5 Finishing

A 20 mm ventilated cavity and the cladding/joinery system must be installed so that it complies with the NZ Building Code. Installation of the cavity, cladding, joinery etc must be in accordance with the relevant supplier and in accordance with the Building Consent, where applicable.

2.6 Quality Assurance

IBS recommends that installers record the installation of IBS RigidRAP®. This may include:

- packing slips to show evidence of delivery
- written notes, and
- meaningful photos.

3. External Wall Bracing

3.1 Scope of Use

IBS supply IBS RigidRAP® for use as an internal or external wall bracing element when used in conjunction with a specific fixing system.

IBS RigidRAP® may be used as a bracing element within the following scope:

In wind zones:

- Up to and including extra high.
- Up to 2.5kPa ULS where the building is specifically engineered.

Building scope:

- New buildings: with timber wall framing complying with NZBC.
- In conjunction with the GIB HandiBrac® method or a Strap Bracing system.
- In conjunction with LVL System - staples, Mitek CPC 80 and SPAX screws.
- In conjunction with LVL System - staples, Simpson Strong-Tie DTT2Z and type 17 screws.
- In conjunction with concrete and timber subfloor applications that comply with the NZBC.
- With all cladding types that comply with NZBC.
- In conjunction with a drained and ventilated nominal 20mm cavity system.
- With aluminium joinery complying with the NZBC.
- IBS RigidRAP® may be used as a bracing element in existing buildings, however in these cases IBS makes no claim as to the bracing value that will be achieved.

If IBS RigidRAP® is to be installed as a bracing element in existing timber framed buildings, the following scope applies:

- Existing timber framed buildings where the designer and/or installer have assured themselves that the existing building is suitable for the intended building work.
- Existing concrete and timber sub-floor structures where the designer and/or installer have assured themselves that the existing building is suitable for the intended building work.

3.2 Limitations

- Allow a minimum of 4 mm between panels 2mm around each sheet both vertically and horizontally to accommodate dimension movement.
- Maximum spacings of wall studs must not exceed 600 mm centres.
- Curved walls, minimum radius 2.5 m are allowable, the IBS RigidRAP® panels must be fixed horizontally onto framing studs with spacing and stud centres dependent on the radius.

When specifying IBS RigidRAP® as a bracing element, the designer must consider site specific conditions and the building with respect to, but not limited to, the following:

- Environmental (exposure) zone
- Wind zone
- Wall bracing table for wind and EQ demand
- Structural design loads
- Structural framing requirements
- Preparation of substrate
- External envelope
- Other materials likely to affect the performance of IBS RigidRAP®.

3.3 IBS RigidRAP® Wall Bracing System

Table 1 provides the bracing value for IBS RigidRAP® with different systems on Timber frames.

Table 2 provides the bracing value for IBS RigidRAP® - XT with different systems on Timber frames.

NOTE:

- For all bracing systems, no product substitution is allowed. Installation must be in accordance with these instructions (unless authorised by IBS). If these requirements are not met, IBS provides no assurance that the bracing capacity (claimed in this design and installation guide) will be achieved.
- The allowable racking resistances for the IBS RigidRAP® systems are applicable to frames lined with IBS RigidRAP® on one side only, unless specified in Table 1 or 2.
- Panels must always be installed vertically if used as bracing sheet.
- Sheets can be installed horizontally if not used as a bracing element.
- All IBS RigidRAP® systems have been tested with no nogs or dwangs.
- Stud sizes and centres will vary depending on height load and loads ref: NZS3604:2011.

The systems may be used on walls of lengths different to those in Table 1 or 2 but is limited to:

- Wall lengths no greater than twice the tested system length.
- For walls greater than the tested system length multiply the length of the wall on a pro-rata basis, up to double the length of the system.
- A wall height less than 1.5 meters shall be referred to a specific engineer design.
- A wall height less than 2.4 meters shall be rated as if they are 2.4 meters high.
- Panels higher than IBS RigidRAP® 2440 mm must be fixed top plate to bottom plate. When walls are higher than 2440 mm, IBS RigidRAP® 2745 or 3050mm sheets can be used.
- A part sheet can be used but must be noggged and nailed.
- Minimum sheet width is 300mm.
- Sheets must overhang bottom plate minimum 15mm , maximum 40mm

3.4 Bracing on Timber and Concrete floors

It should be noted that in NZS3604:2011, the bracing resistance of elements on concrete flooring is 150 BUs/m and to 120 BUs/m on timber floors.

3.5 Vertical joints and Horizontal joints

- Serviceability of the joints may be affected if - at the time the timber framing is installed - its moisture content is greater than 18%.
- For wall heights greater than 3050 mm, horizontal wall joints are permitted, provided the panel joint is over solid blocking of the same gauge as the studs.
- All joints, must be sealed with an IBS approved self- adhesive “flashing tape” as specified in section 4. IBS recommends 75mm flashing tape on vertical joints and 150mm flashing tape or a proprietary Z flashing for horizontal joints.
- Steel fixings and fastenings must be in accordance with table 4.1, NZS 3604: 2011.
- Do not install IBS RigidRAP® if the building paper has delaminated from the OSB sheet.
- For bracing: _ sheets must be installed vertically.
 _ sheets can be upside down.

3.6 Bracing fastening

- Nails or screws are placed at 150mm centres around the edges and 300mm through the middle stud.
- For extra high wind zones, sheets should be nailed off at 150mm centres.
- IBS RigidRAP® must be fixed top plate to bottom plate, we recommend 75mm spaced fixings on top and bottom plate if uplift top plate/stud mechanical connections are not used - see Section 3.9 “Top Plate / Stud Mechanical Fixings”
- Panels must always be installed vertically if used as a bracing element.
- A part sheet can be used but must be nogged and nailed.
- Minimum sheet width is 300 mm.

3.7 IBS RigidRAP® Bracing Capacity (Timber Frames)

The following table provides the bracing value for the different systems				
Table 1	Concrete Slab		Timber Floor	
	Wind	EQ	Wind	EQ
System 1: RRT01 IBS RigidRAP® OSB - 300 mm x 2400 mm wall with GIB HandiBrac® Fixing 30 mm x 2.5 mm Galv clouts	49 BU/m	58 BU/m	49 BU/m	58 BU/m
System 2: RRT02 IBS RigidRAP® OSB - 400 mm x 2400 mm wall with GIB HandiBrac® Fixing 30 mm x 2.5 mm Galv clouts.	70 BU/m	79 BU/m	70 BU/m	79 BU/m
System 3: RRT03 IBS RigidRAP® OSB - 600 mm x 2400 mm wall with GIB HandiBrac® Fixing 30 mm x 2.5 mm Galv clouts	76 BU/m	81 BU/m	76 BU/m	81 BU/m
System 4: RRT04 IBS RigidRAP® OSB - 1200 mm x 2400 mm wall with GIB HandiBrac® Fixing 30 mm x 2.5 mm Galv clouts	131 BU/m	107 BU/m	131 BU/m	107 BU/m
System 5: RRT05 IBS RigidRAP® OSB - 2400 mm x 2400 mm wall with GIB HandiBrac® Fixing 30 mm x 2.5 mm Galv clouts	108 BU/m	89 BU/m	108 BU/m	89 BU/m
System 6: RRT06 IBS RigidRAP® OSB - 1200 mm x 2400 mm wall without GIB HandiBrac® Fixing 30 mm x 2.5 mm Galv clouts	93 BU/m	78 BU/m	93 BU/m	78 BU/m
System 7: RRTG07 IBS RigidRAP® OSB - 400 mm x 2400 mm wall with GIB®HandiBrac® GIB® standard 10 mm board on the inside IBS RigidRAP® Fixing- 30 mm x 2.5 mm Galv clouts GIB® standard 10 mm board Fixings - 32 mm x 6 gauge GIB Grabber high thread drywall screw	94 BU/m	104 BU/m	94 BU/m	104 BU/m
System 8: RRTG08 IBS RigidRAP® OSB - 600 mm x 2400 mm wall with GIB®HandiBrac® GIB® standard 10 mm board on the inside IBS RigidRAP® Fixing- 30 mm x 2.5 mm Galv clouts GIB® standard 10 mm board Fixings - 32 mm x 6 gauge GIB Grabber high thread drywall screws	130 BU/m	130 BU/m	120 BU/m	120 BU/m
System 9: RRTG09 IBS RigidRAP® OSB - 1200 mm x 2400 mm wall with GIB® HandiBrac® GIB® standard 10 mm board on the inside IBS RigidRAP® Fixing- 30 mm x 2.5 mm Galv clouts GIB® standard 10 mm board Fixings - 32 mm x 6 gauge GIB Grabber high thread drywall screw	150 BU/m	150 BU/m	130 BU/m	130 BU/m

SYSTEM 1

IBS RigidRAP® 300 x 2400 mm wall using GIB® HANDIBRAC®

Wall construction:

- 90 x 45 MSG8 studs.
- IBS RigidRAP® 8mm panel one side.
- 30 x 2.5 mm galv clouts at 150 mm centres around the perimeter – 75mm centres on top and bottom plates if uplift top plate/stud mechanical connections are not used.
- GIB® HandiBrac® hold down brackets fixed to each end-to-end studs and to bottom plate with concrete hold downs as per manufacturer's specifications.
- Tested on a concrete floor with M12 hold down bolts.

FIG 1

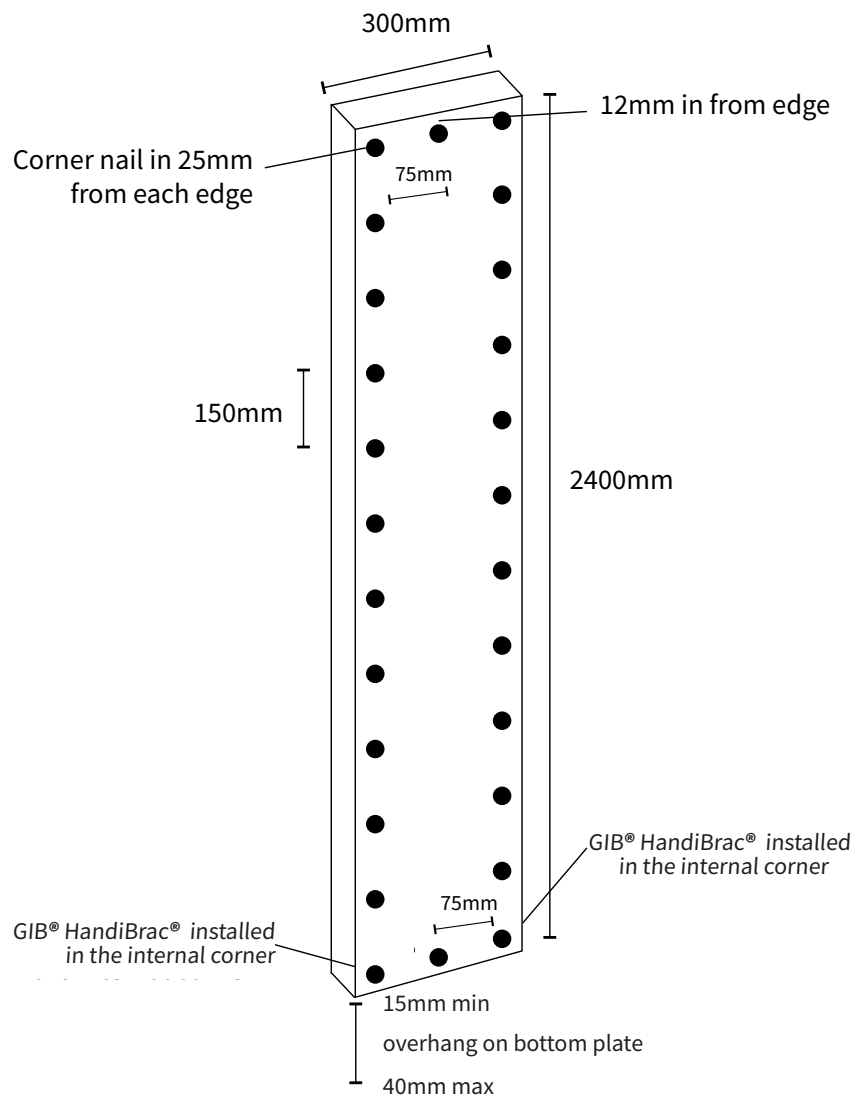

SYSTEM 2

IBS RigidRAP® 400 x 2400 mm wall using GIB® HANDIBRAC®

Wall construction:

- 90 x 45 MSG8 studs.
- IBS RigidRAP® 8mm panel one side.
- 30 x 2.5 mm galv clouts at 150 mm centres around the perimeter – 75mm centres on top and bottom plates if uplift top plate/stud mechanical connections are not used.
- GIB® HandiBrac® hold down brackets fixed to each end-to-end studs and to bottom plate with concrete hold downs as per manufacturer’s specifications.
- Tested on a concrete floor with M12 hold down bolts.

FIG 2

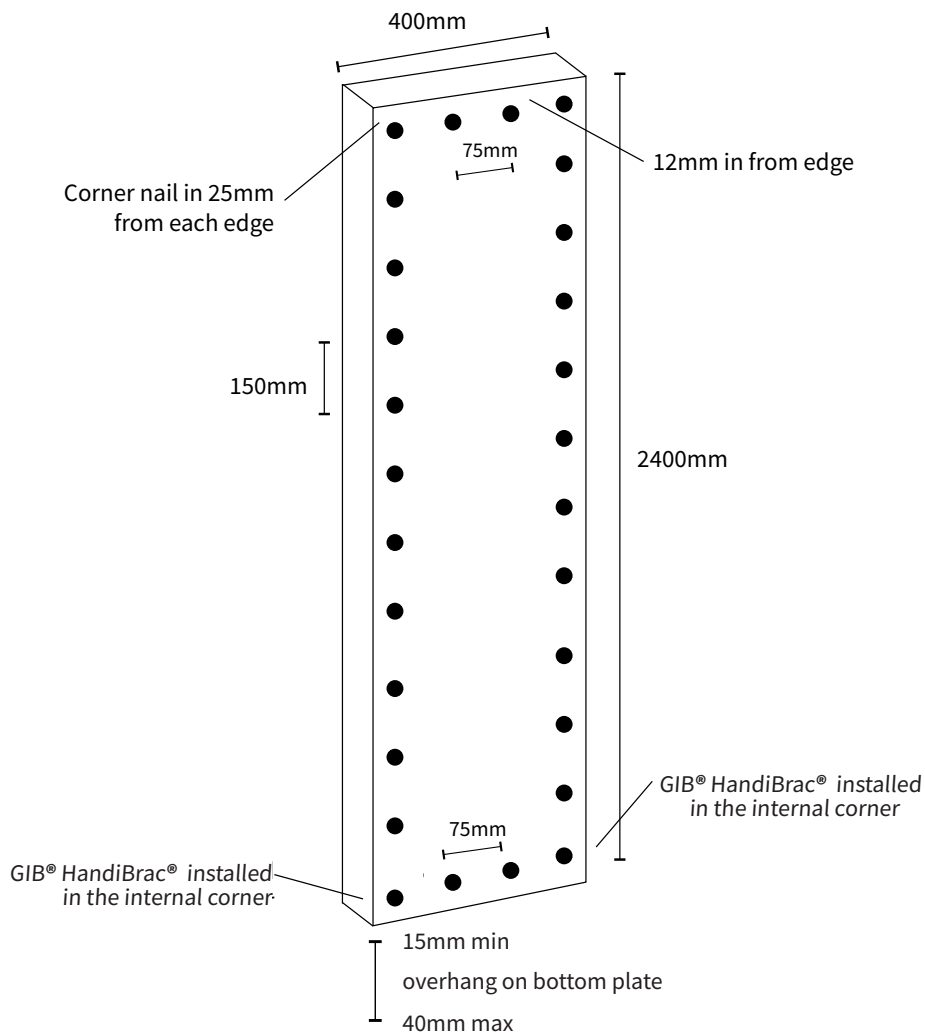

SYSTEM 3

IBS RigidRAP® 600 x 2400 mm wall using GIB® HANDIBRAC®

Wall construction:

- 90 x 45 MSG8 studs.
- IBS RigidRAP® 8mm panel one side.
- 30 x 2.5 mm galv clouts at 150 mm centres around the perimeter – 75mm centres on top and bottom plates if uplift top plate/stud mechanical connections are not used.
- GIB® HandiBrac® hold down brackets fixed to each end-to-end studs and to bottom plate with concrete hold downs as per manufacturer's specifications.
- Tested on a concrete floor with M12 hold down bolts.

FIG 3

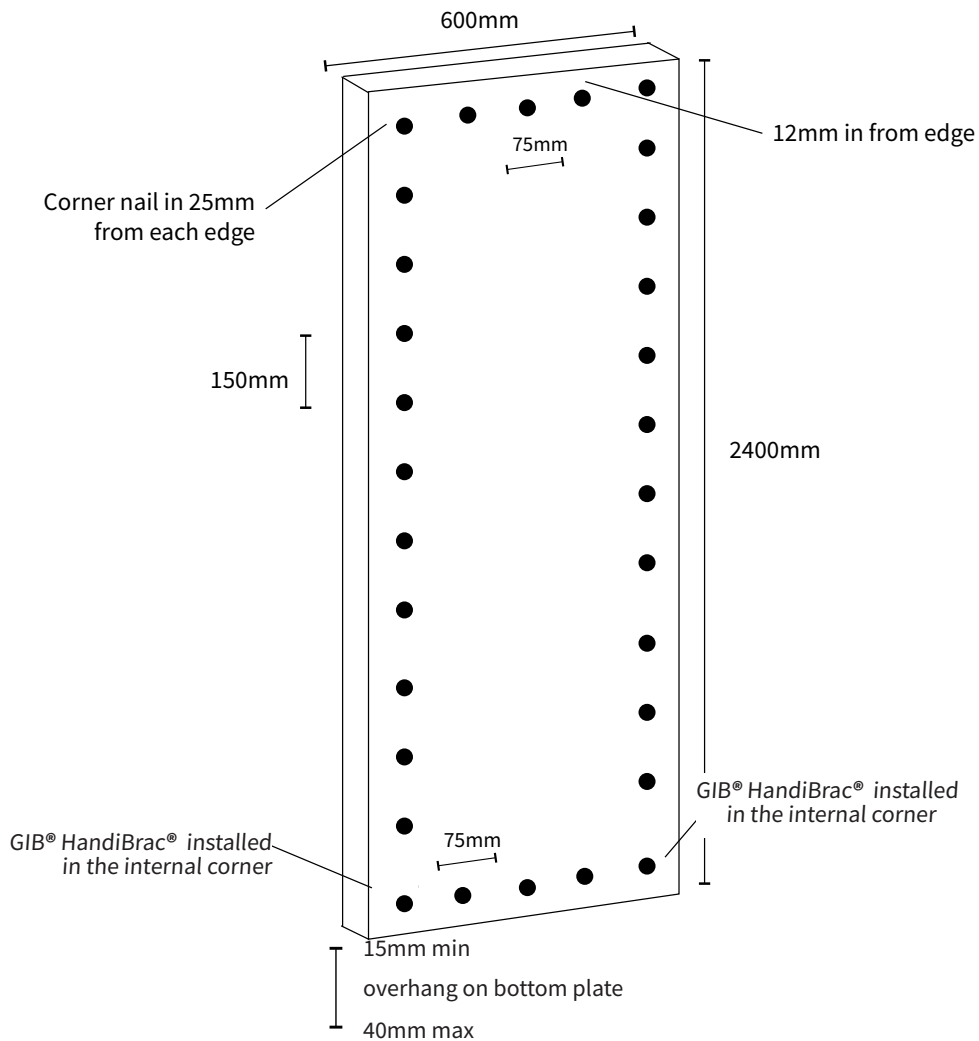

SYSTEM 4

IBS RigidRAP® 1200 x 2400 mm wall using GIB® HANDIBRAC®

Wall construction:

- 90 x 45 MSG8 studs (600 mm centres) plates.
- IBS RigidRAP® 8mm panel one side.
- 30 x 2.5 mm galv clouts at 150 mm centres around the perimeter – 75mm centres on top and bottom plates if uplift top plate/stud mechanical connections are not used.
- GIB® HandiBrac® hold down brackets fixed to each end-to-end studs and to bottom plate with concrete hold downs as per manufacturer’s specifications.
- Tested on a concrete floor with M12 hold-down bolts.

FIG 4

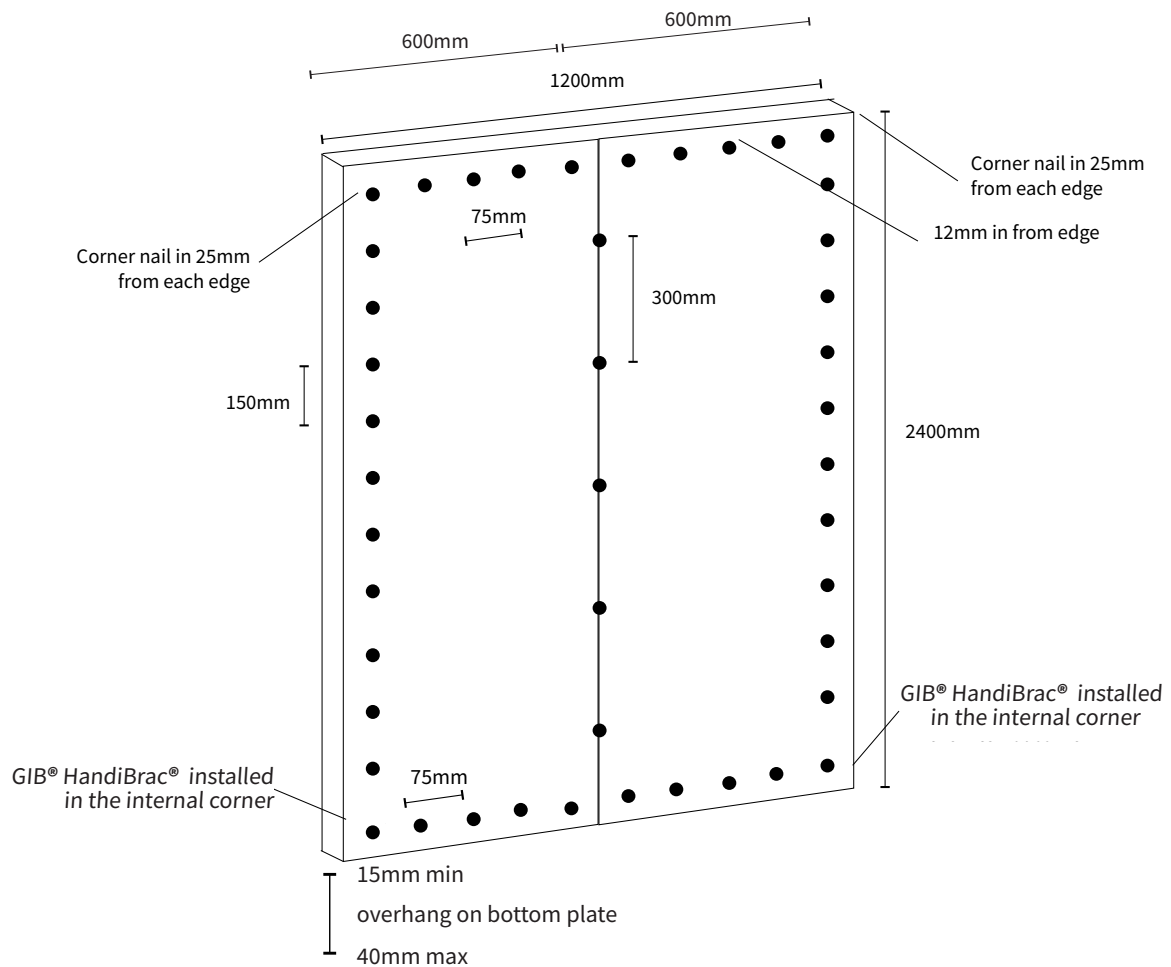

SYSTEM 5

IBS RigidRAP® 1200 x 2400 mm wall using GIB® HANDIBRAC®

Wall construction:

- 90 x 45 MSG8 studs.
- IBS RigidRAP® 8mm panel one side.
- 30 x 2.5 mm galv clouts at 150 mm centres around the perimeter – 75mm centres on top and bottom plates if uplift top plate/stud mechanical connections are not used.
- GIB® HandiBrac® hold down brackets fixed to each end-to-end studs and to bottom plate with concrete hold downs as per manufacturer’s specifications.
- Tested on a concrete floor with M12 hold down bolts.

FIG 5

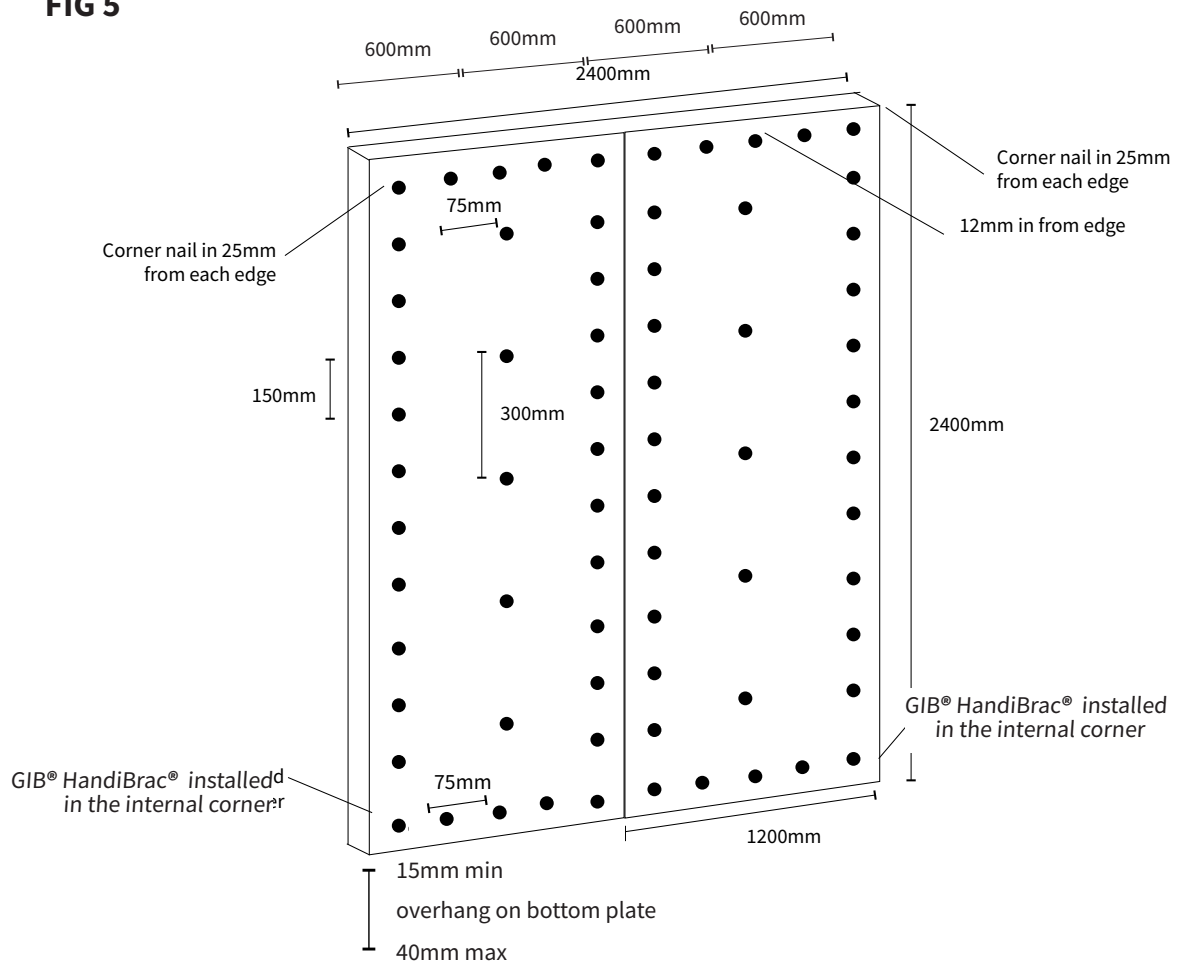

SYSTEM 6

IBS RigidRAP® 1200 x 2400 mm wall

Wall construction:

- 90 x 45 MSG8 studs (600 mm centres) plates.
- IBS RigidRAP® 8mm panel one side.
- 30 x 2.5 mm galv clouts at 150 mm centres around the perimeter – 75mm centres on top and bottom plates if uplift top plate/stud mechanical connections are not used.
- No hold down brackets

FIG 6

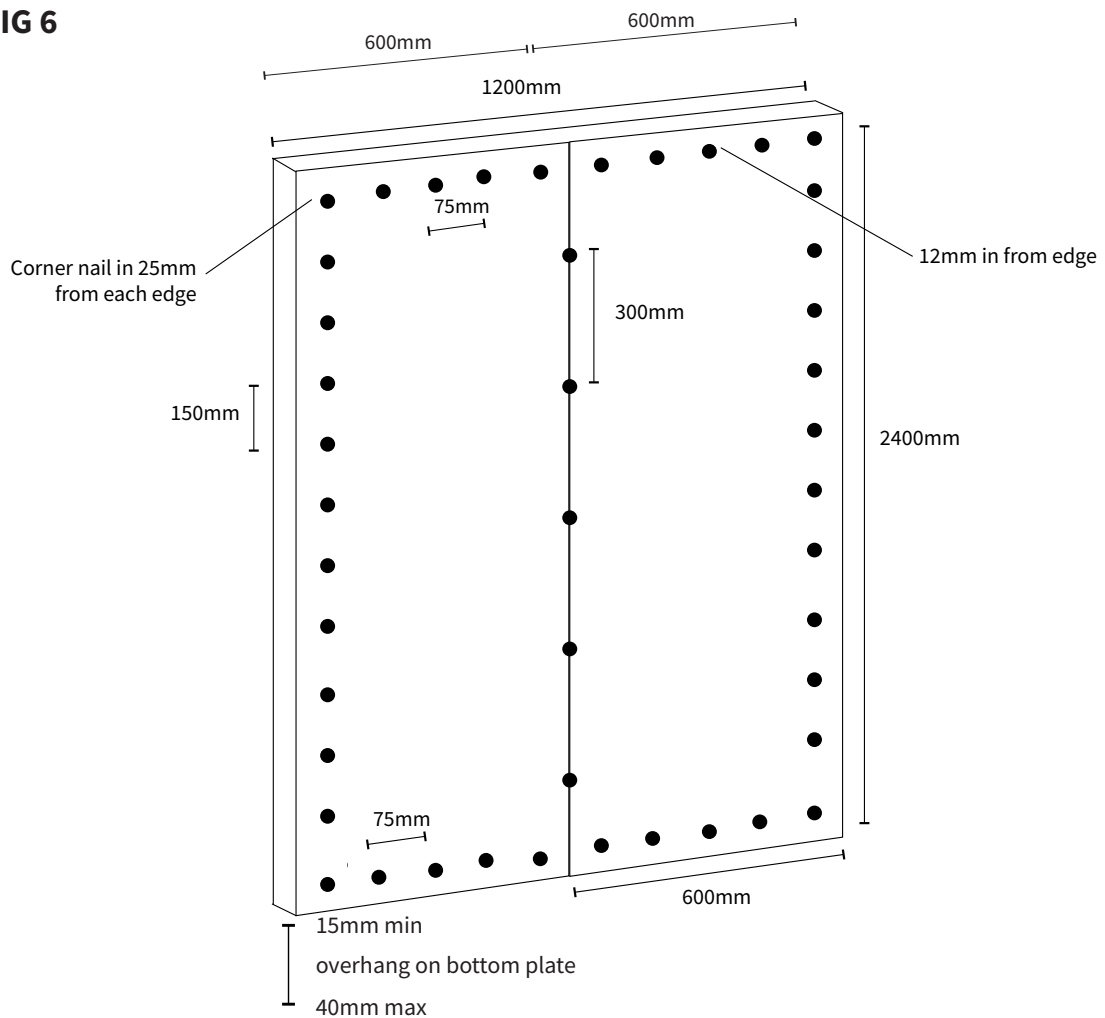

SYSTEM 7

IBS RigidRAP® 400 x 2400 mm wall using GIB HANDIBRAC® and GIB® 10mm Standard Board

Wall construction:

- 90 x 45 MSG8 studs.
- IBS RigidRAP® 8mm panel outside.
- GIB® standard 10 mm board on the inside
- 30 x 2.5 mm galv clouts at 150 mm centres around the perimeter – 75mm centres on top and bottom plates if uplift top plate/stud mechanical connections are not used.
- GIB® HandiBrac® hold down brackets fixed to each end-to-end studs and to bottom plate with concrete hold downs as per manufacturer's specifications.
- Tested on a concrete floor with M12 hold down bolts.

FIG 7

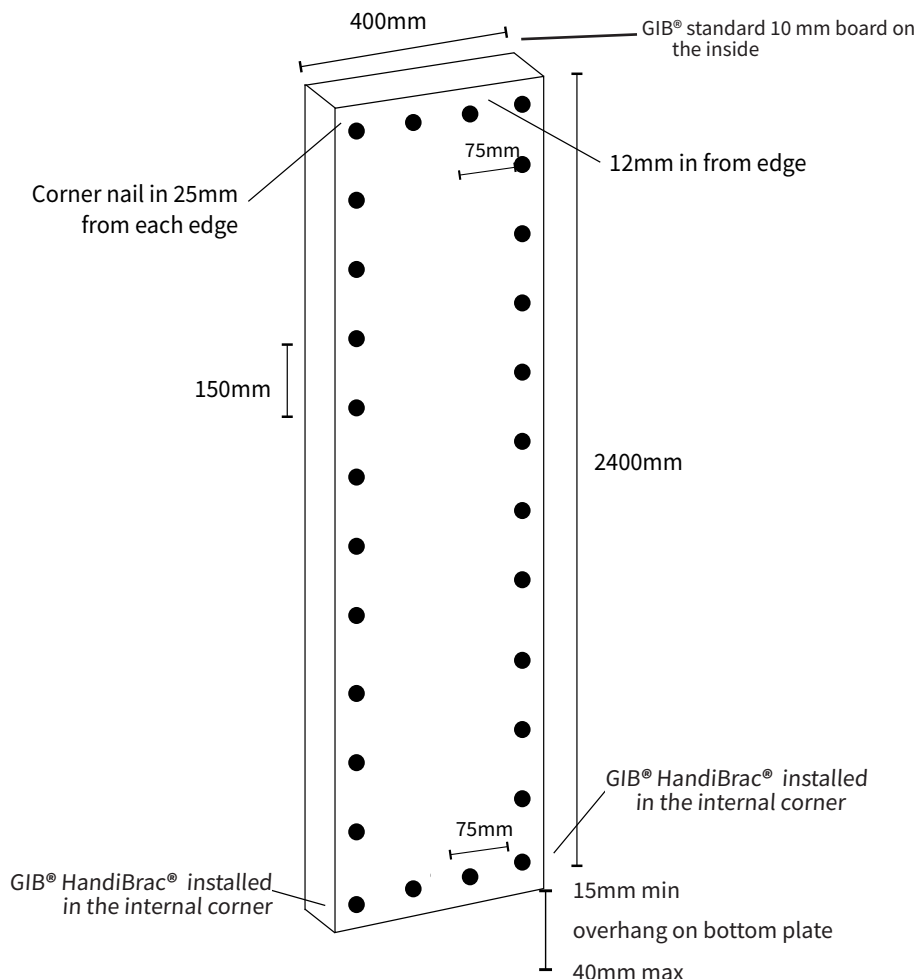

Note - Fixing of GIB® Standard to timber framing

The GIB® Standard was fastened to the framing with 32mm long by 6 gauge GIB® Grabber® high thread drywall screws spaced at 150mm centres. In the corners of the panels the fasteners spacing for the GIB® Standard was decreased to 50mm centres.

SYSTEM 8

IBS RigidRAP® 600 x 2400 mm wall using GIB® HANDIBRAC® and GIB® 10mm Standard Board

Wall construction:

- 90 x 45 MSG8 studs.
- IBS RigidRAP® 8mm panel outside.
- GIB® standard 10 mm board on the inside.
- 30 x 2.5 mm galv clouts at 150 mm centres around the perimeter – 75mm centres on top and bottom plates if uplift top plate/stud mechanical connections are not used.
- GIB® HandiBrac® hold down brackets fixed to each end-to-end studs and to bottom plate with concrete hold downs as per manufacturer’s specifications.
- Tested on a concrete floor with M12 hold down bolts.

FIG 8

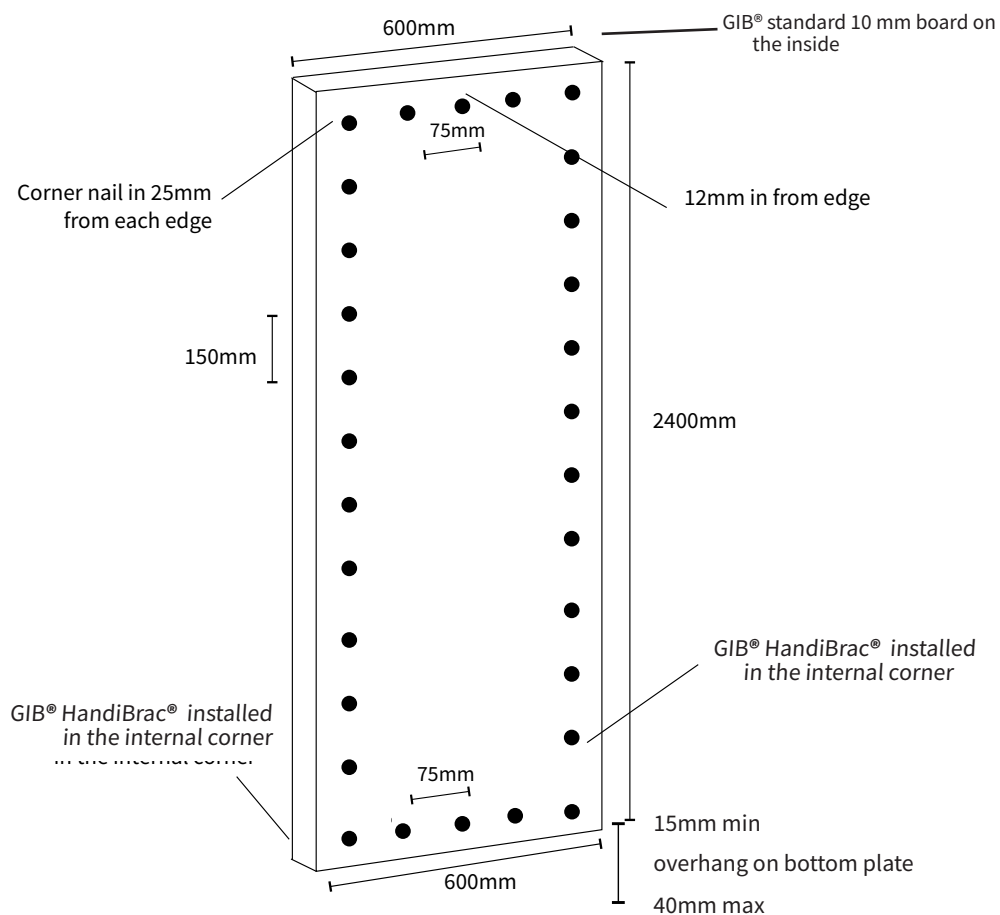

Note - Fixing of GIB® Standard to timber framing

The GIB® Standard was fastened to the framing with 32mm long by 6 gauge GIB® Grabber® high thread drywall screws spaced at 150mm centres. In the corners of the panels the fasteners spacing for the GIB® Standard was decreased to 50mm centres.

SYSTEM 9

IBS RigidRAP® 1200 x 2400 mm wall using GIB HANDIBRAC® and GIB® 10mm Standard Board

Wall construction:

- 90 x 45 MSG8 studs (600 mm centres) plates.
- IBS RigidRAP® 8mm panel outside.
- GIB® standard 10 mm board on the inside.
- 30 x 2.5 mm galv clouts at 150 mm centres around the perimeter – 75mm centres on top and bottom plates if uplift top plate/stud mechanical connections are not used.
- GIB® HandiBrac® hold down brackets fixed to each end-to-end studs and to bottom plate with concrete hold downs as per manufacturer’s specifications.
- Tested on a concrete floor with M12 hold down bolts.

FIG 9

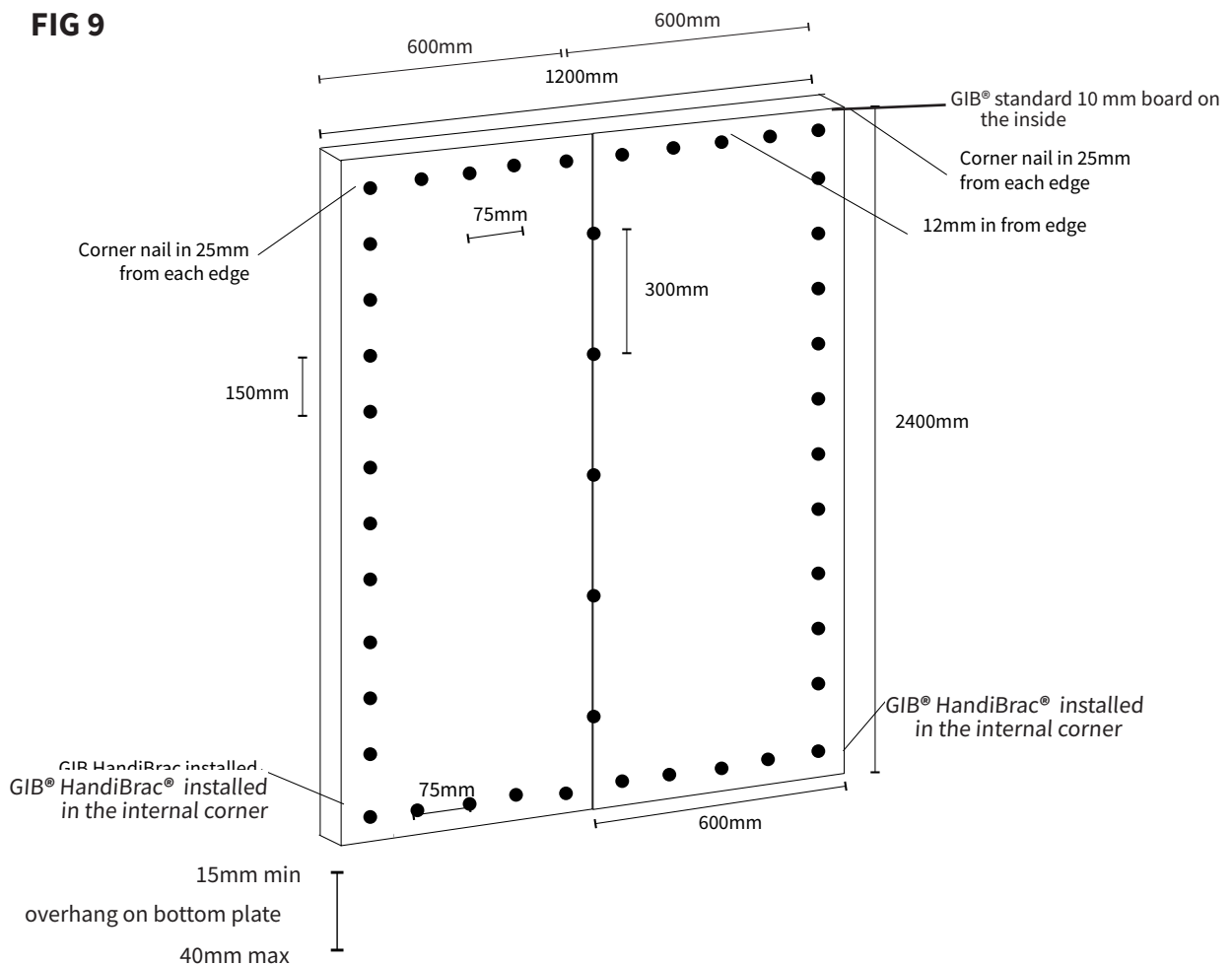

Note - Fixing of GIB® Standard to timber framing

The GIB® Standard was fastened to the framing with 32mm long by 6 gauge GIB® Grabber® high thread drywall screws spaced at 150mm centres. In the corners of the panels the fasteners spacing for the GIB® Standard was decreased to 50mm centres.

3.8 IBS RigidRAP® - XT Bracing Capacity (Timber Frames)

The following table provides the bracing value for the different systems				
Table 2	Concrete Slab		Timber Floor	
	Wind	EQ	Wind	EQ
<p>System 10 - XTT10 IBS RigidRAP® - XT</p> <p>OSB - 600mm x 2400mm wall fitted on the inside with GIB® HandiBrac® Fixing- 50mm x 2.8mm Galv nails</p>	60 BU/m	70 BU/m	60 BU/m	70 BU/m
<p>System 11 - XTT11 IBS RigidRAP® - XT</p> <p>OSB - 1200mm x 2400mm wall fitted on the inside with GIB® HandiBrac® Fixing- 50mm x 2.8mm Galv nails</p>	78 BU/m	71 BU/m	78 BU/m	71 BU/m
<p>System 12 - XTTG12 IBS RigidRAP® - XT</p> <p>OSB - 300mm x 2400mm wall fitted on the inside with GIB® HandiBrac® GIB® standard 10 mm board on the inside IBS RigidRAP® - XT Fixing- 50mm x 2.8mm Galv nails GIB® standard 10 mm board Fixings - 32 mm x 6 gauge GIB Grabber high thread drywall screw</p>	78 BU/m	96 BU/m	78 BU/m	96BU/m
<p>System 13 - XTTG13 IBS RigidRAP® - XT</p> <p>OSB - 400mm x 2400mm wall fitted on the inside with GIB® HandiBrac® GIB® standard 10 mm board on the inside IBS RigidRAP® - XT Fixing- 50mm x 2.8mm Galv nails GIB® standard 10 mm board Fixings - 32 mm x 6 gauge GIB Grabber high thread drywall screw</p>	94 BU/m	110 BU/m	94 BU/m	110 BU/m
<p>System 14 - XTTG14 IBS RigidRAP® - XT</p> <p>OSB - 600mm x 2400mm wall fitted on the inside with GIB® HandiBrac® GIB® standard 10 mm board on the inside IBS RigidRAP® - XT Fixing- 50mm x 2.8mm Galv nails GIB® standard 10 mm board Fixings - 32 mm x 6 gauge GIB Grabber high thread drywall screw</p>	123 BU/m	123 BU/m	123 BU/m	123 BU/m
<p>System 15 - XTTG15 IBS RigidRAP® - XT</p> <p>OSB - 1200mm x 2400mm wall fitted on the inside with GIB® HandiBrac® GIB® standard 10 mm board on the inside IBS RigidRAP® - XT Fixing 50mm x 2.8mm Galv nails GIB® standard 10 mm board Fixings - 32 mm x 6 gauge GIB Grabber high thread drywall screw</p>	165 BU/m	142 BU/m	165 BU/m	142 BU/m

Note: IBS RigidRAP-XT is made up as follows:

- 8mm OSB
- Laminated Building Paper on OSB
- 10 mm EPS (acting as the thermal break) on the rear.

SYSTEM 10

IBS RigidRAP-XT® 600 x 2400 mm wall using GIB® HANDIBRAC®

Wall construction:

- 90 x 45 MSG8 studs.
- IBS RigidRAP® - XT 18mm panel one side.
- 50 x 2.8 mm galv clouts at 150 mm centres around the perimeter – 75mm centres on top and bottom plates if uplift top plate/stud mechanical connections are not used
- GIB® HandiBrac® hold down brackets fixed to each end-to-end studs and to bottom plate with concrete hold downs as per manufacturer's specifications.
- Tested on a concrete floor with M12 hold down bolts.

FIG 10

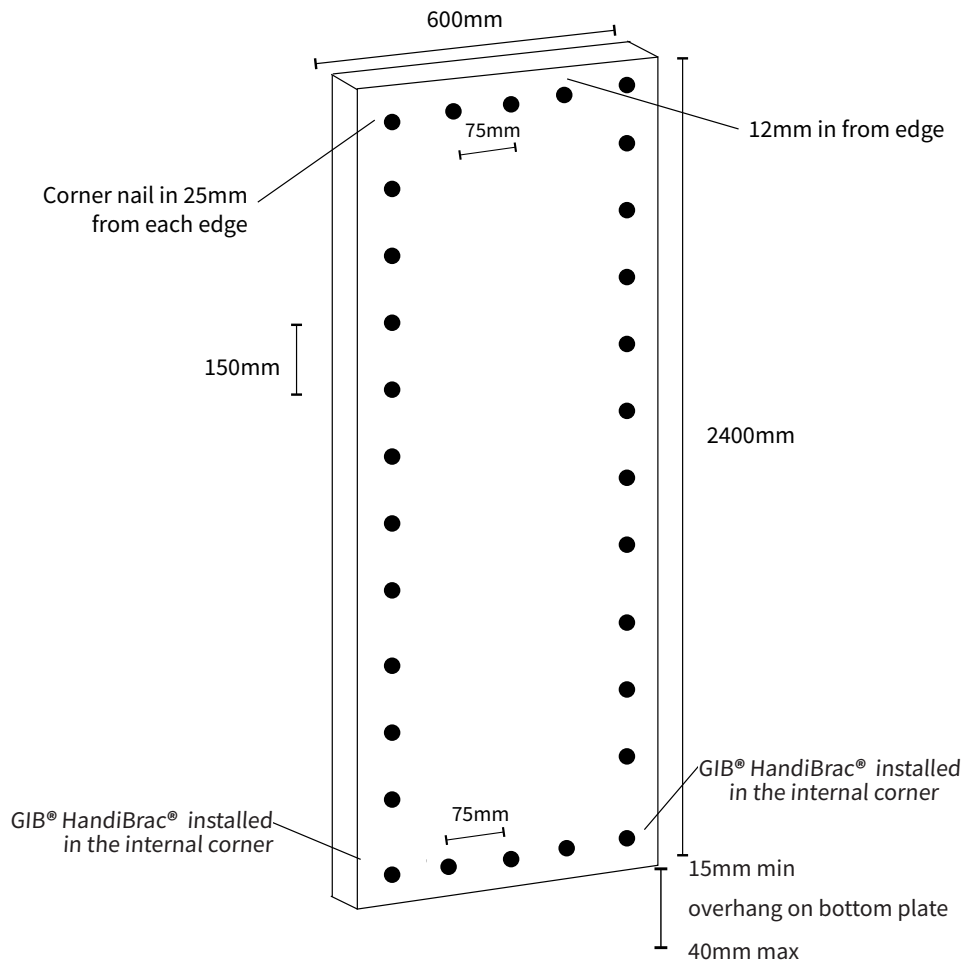

SYSTEM 11

IBS RigidRAP® - XT 1200 x 2400 mm wall using GIB® HANDIBRAC®

Wall construction:

- 90 x 45 MSG8 studs (600 mm centres) plates.
- IBS RigidRAP® - XT 18mm panel one side.
- 50 x 2.8 mm galv clouts at 150 mm centres around the perimeter – 75mm centres on top and bottom plates if uplift top plate/stud mechanical connections are not used
- GIB® HandiBrac® hold down brackets fixed to each end-to-end studs and to bottom plate with concrete hold downs as per manufacturer’s specifications.
- Tested on a concrete floor with M12 hold-down bolts.

FIG 11

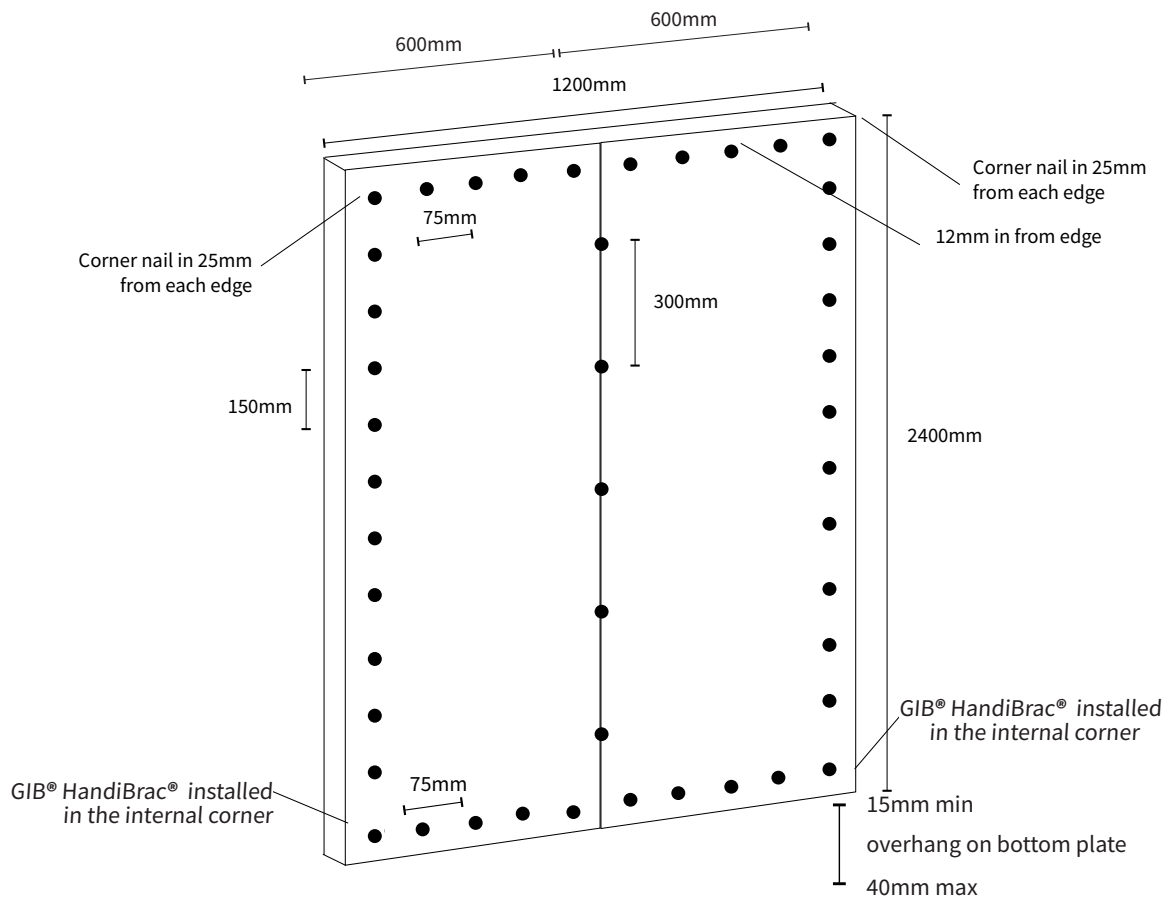

SYSTEM 12

IBS RigidRAP® - XT 300 x 2400 mm wall using GIB HANDIBRAC® and GIB® 10mm Standard Board

Wall construction:

- 90 x 45 MSG8 studs.
- IBS RigidRAP® - XT 18mm panel outside.
- GIB® standard 10 mm board on the inside.
- 50 x 2.8 mm galv clouts at 150 mm centres around the perimeter – 75mm centres on top and bottom plates if uplift top plate/stud mechanical connections are not used
- GIB® HandiBrac® hold down brackets fixed to each end-to-end studs and to bottom plate with concrete hold downs as per manufacturer's specifications.
- Tested on a concrete floor with M12 hold down bolts.

FIG 12

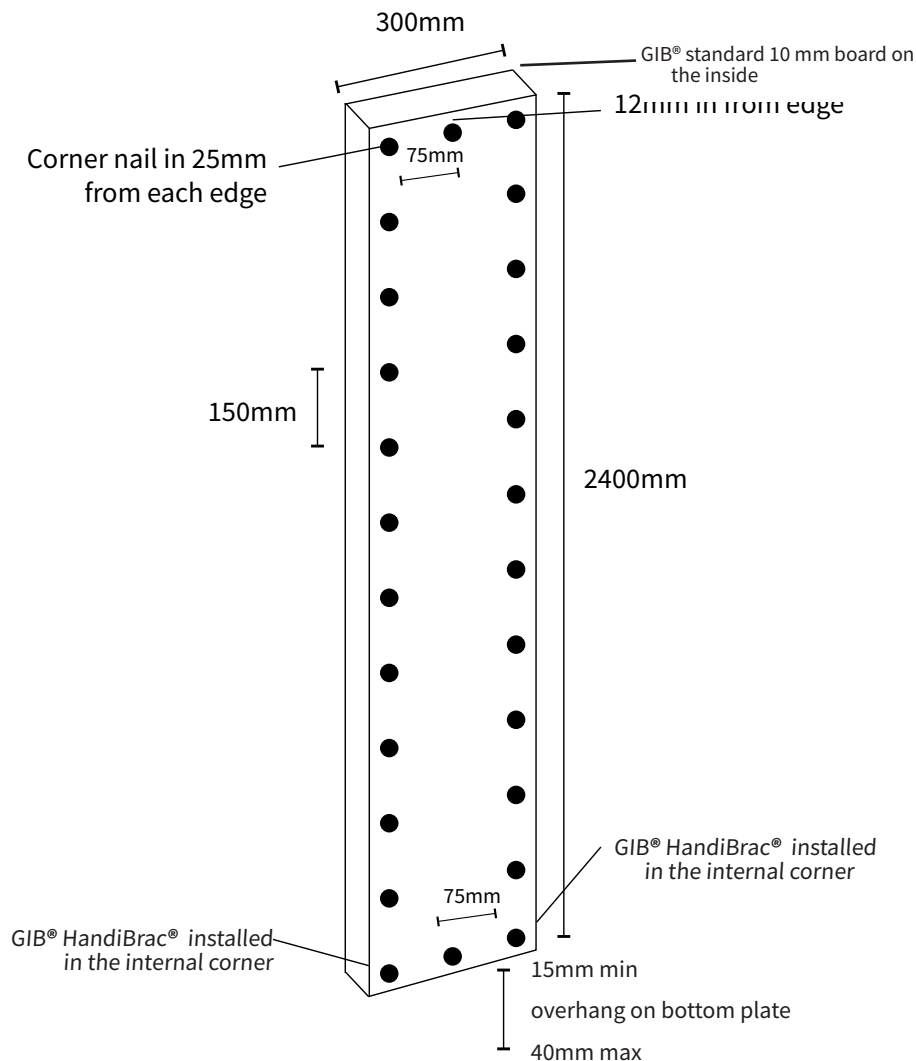

Note - Fixing of GIB® Standard to timber framing

The GIB® Standard was fastened to the framing with 32mm long by 6 gauge GIB® Grabber® high thread drywall screws spaced at 150mm centres. In the corners of the panels the fasteners spacing for the GIB® Standard was decreased to 50mm centres.

SYSTEM 13

IBS RigidRAP® - XT 400 x 2400 mm wall using GIB HANDIBRAC® and GIB® 10mm Standard Board

Wall construction:

- 90 x 45 MSG8 studs (600 mm centres) plates.
- IBS RigidRAP® - XT 18mm panel outside.
- GIB® standard 10 mm board on the inside.
- 50 x 2.8 mm galv clouts at 150 mm centres around the perimeter – 75mm centres on top and bottom plates if uplift top plate/stud mechanical connections are not used
- GIB® HandiBrac® hold down brackets fixed to each end-to-end studs and to bottom plate with concrete hold downs as per manufacturer’s specifications.
- Tested on a concrete floor with M12 hold-down bolts.

FIG 13

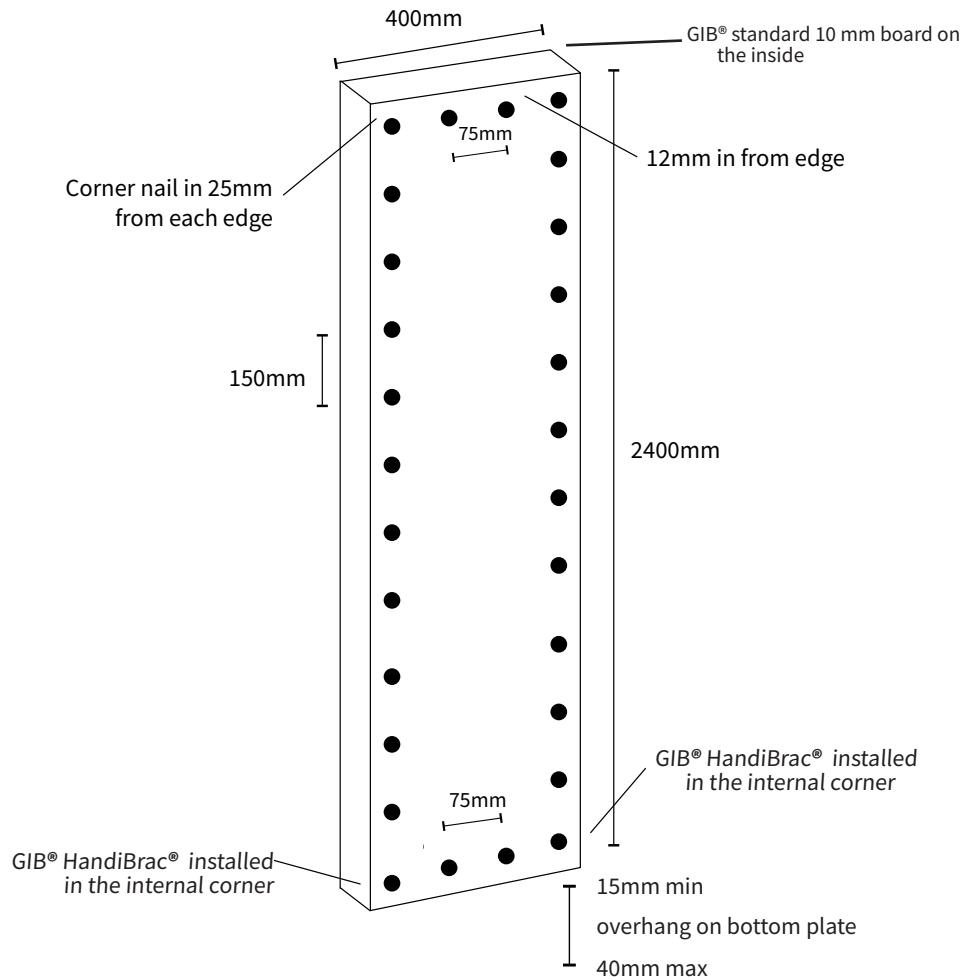

Note - Fixing of GIB® Standard to timber framing

The GIB® Standard was fastened to the framing with 32mm long by 6 gauge GIB® Grabber® high thread drywall screws spaced at 150mm centres. In the corners of the panels the fasteners spacing for the GIB® Standard was decreased to 50mm centres.

SYSTEM 14

IBS RigidRAP® - XT 600 x 2400 mm wall using GIB HANDIBRAC® and GIB® 10mm Standard Board

Wall construction:

- 90 x 45 MSG8 studs.
- IBS RigidRAP® - XT 18mm panel outside.
- GIB® standard 10 mm board on the inside.
- 50 x 2.8 mm galv clouts at 150 mm centres around the perimeter – 75mm centres on top and bottom plates if uplift top plate/stud mechanical connections are not used
- GIB® HandiBrac® hold down brackets fixed to each end-to-end studs and to bottom plate with concrete hold downs as per manufacturer’s specifications.
- Tested on a concrete floor with M12 hold down bolts.

FIG 14

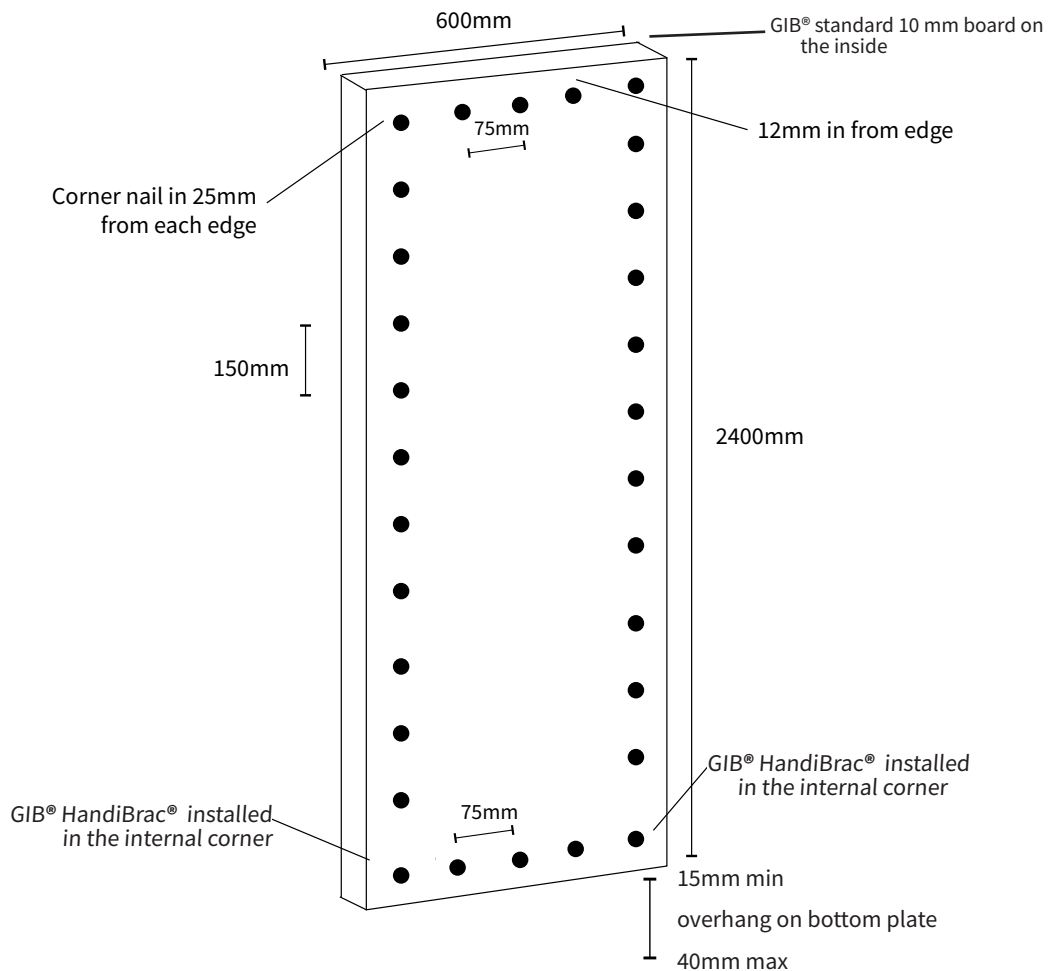

Note - Fixing of GIB® Standard to timber framing

The GIB® Standard was fastened to the framing with 32mm long by 6 gauge GIB® Grabber® high thread drywall screws spaced at 150mm centres. In the corners of the panels the fasteners spacing for the GIB® Standard was decreased to 50mm centres.

SYSTEM 15

IBS RigidRAP® - XT 1200 x 2400 mm wall using GIB HANDIBRAC® and GIB® 10mm Standard Board

Wall construction:

- 90 x 45 MSG8 studs (600 mm centres) plates.
- IBS RigidRAP® - XT 18mm panel outside.
- GIB® standard 10 mm board on the inside.
- 50 x 2.8 mm galv clouts at 150 mm centres around the perimeter – 75mm centres on top and bottom plates if uplift top plate/stud mechanical connections are not used
- GIB® HandiBrac® hold down brackets fixed to each end-to-end studs and to bottom plate with concrete hold downs as per manufacturer’s specifications.
- Tested on a concrete floor with M12 hold-down bolts.

FIG 15

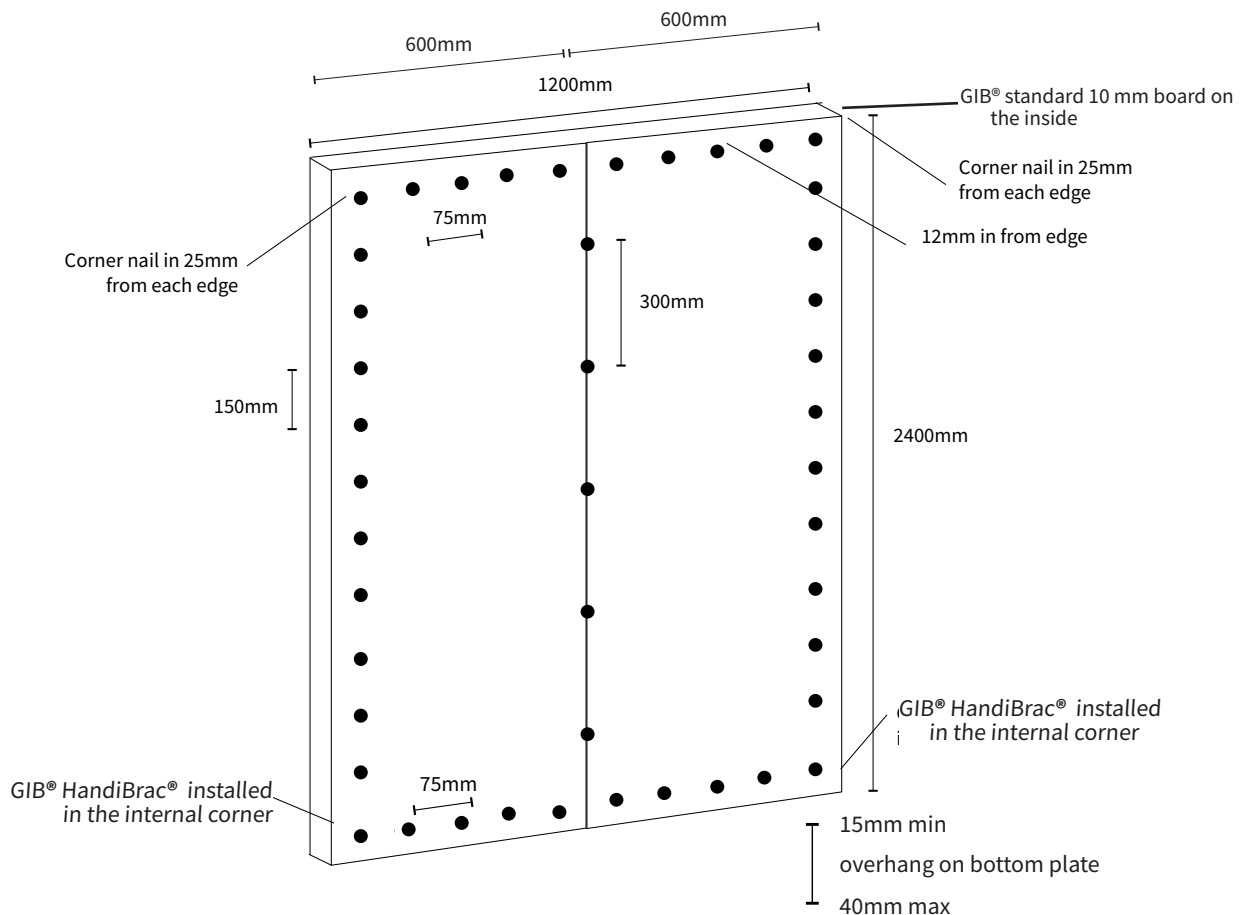

Note - Fixing of GIB® Standard to timber framing

The GIB® Standard was fastened to the framing with 32mm long by 6 gauge GIB® Grabber® high thread drywall screws spaced at 150mm centres. In the corners of the panels the fasteners spacing for the GIB® Standard was decreased to 50mm centres.

3.9 Top Plate to Rafter or Truss Connections

Connections

RigidRAP® sheathed wall frames transfer these uplift loads to the bottom plates; the IBS RigidRAP® acting in tension as a continuous cycle rod. Refer to NZS3604:2011 Table 8.18 for uplift connections between top plate and roof framing. Rafter/truss spacing is determined by the loaded dimensions.

Top Plate / Stud Mechanical Fixings

Uplift top plate/stud mechanical connections in accordance with NZS3604: 2011 up to 7.5kN can be omitted where IBS RigidRAP® and fixings are installed (top and bottom plates) at a maximum spacing of 75 mm.

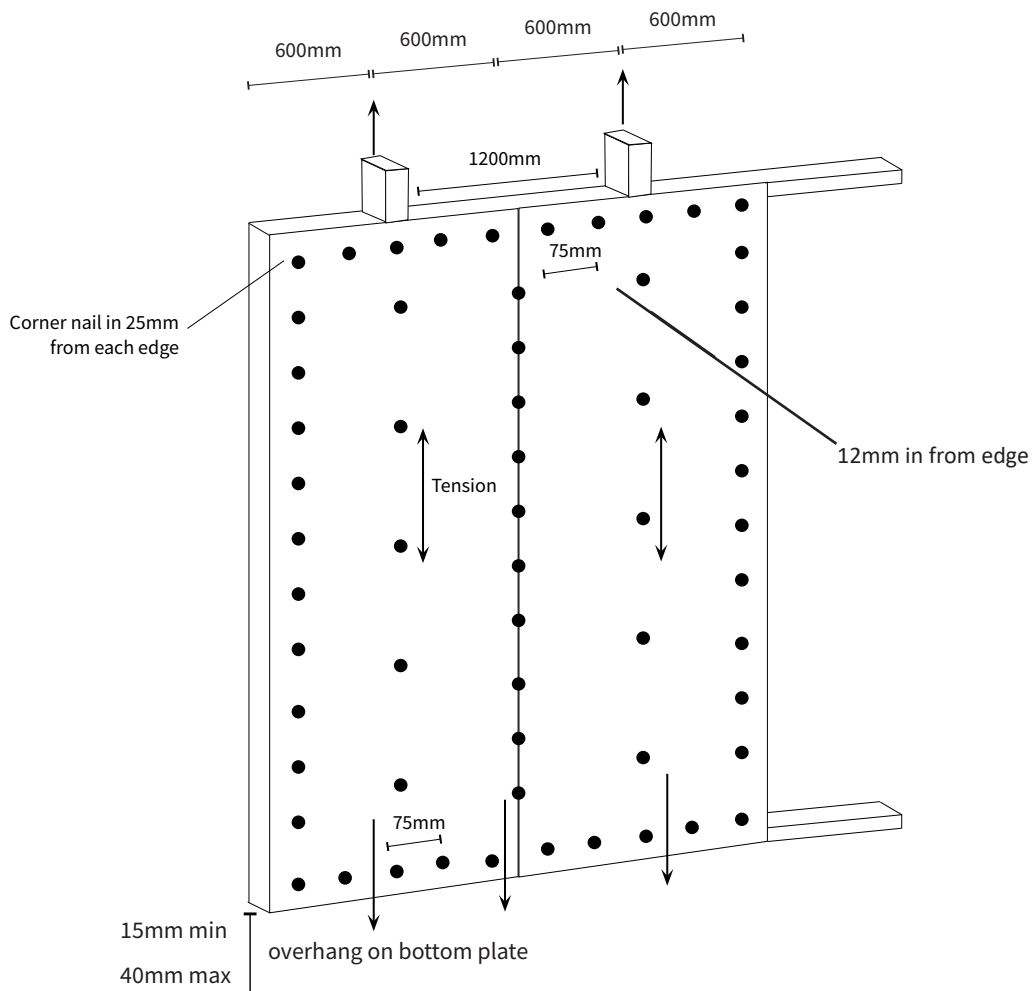

Bottom plate to floor or sub floor connection as per NZS 3604:2011.

Allowable uplift resistance (kN/rafter)	Fastener spacing (mm) top and bottom plates
7.5	75
8.5	40

3.10 Lintel Tie Down Details

Where the uplift does not exceed 7.5kN, the following strap fixing detail may be used as an alternate to 7.5kN strap fixing detailed in NZS3604: 2011, FIG 8.12.

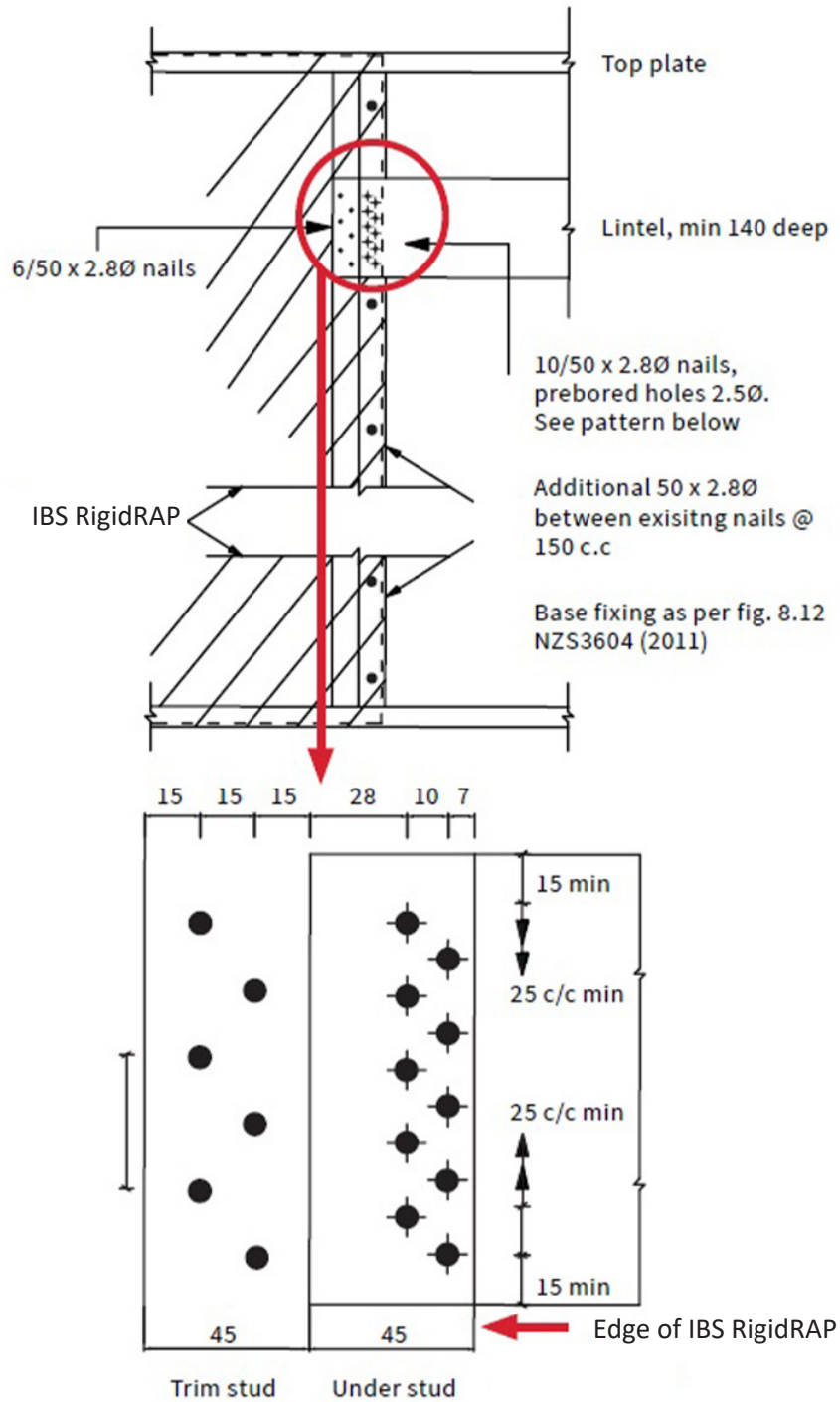

3.11 Fixings - RigidRAP® (Timber Frames)

Fixing	Exposure Zone
Type 304 S/ Steel, Gauge 8 x 25 Surefix Screws	All exposure zones
45 x 2.5 S/Steel AnnularGrooved Nails	All exposure zones
30 x 2.5 Galv Clouts	Exposure zone B & C only

Bottom Plate Fixing	Exposure Zone
GIB®HandiBrac® Use supplied hold-down bolts	Steel fixing as per table 4:1 NZS3604:2011

- Nails can be power driven.
- Round or D head nails.
- Sheets must overhang botom plate min 15mm, max 40mm.
- Finish flush.
- Do not puncture the paper.

3.12 Fixings - RigidRAP® - XT (Timber Frames)

Fixing	Exposure Zone
45 x 2.5 S/Steel AnnularGrooved Nails	All exposure zones
50 x 2.8 mm galv clouts	Exposure zone B & C only

Bottom Plate Fixing	Exposure Zone
GIB® HandiBrac® Use supplied hold-down bolts	Steel fixing as per table 4:1 NZS3604:2011

- Nails can be power driven.
- Round or D head nails.
- Sheets must overhang botom plate min 15mm, max 40mm.
- Finish flush.
- Do not puncture the paper.

3.13 Mechanical Connections (Uplift & Hold Down)

Connections	Exposure Zone
Cyclone ties (304-2B Stainless Steel) Nails SS 30 mm x 3.15 mm in diameter	All exposure zones
1 x 25 - Sheet Brace Strap (304-2B Stainless Steel) Nails SS 6/30 x 3.15 diameter nails per strap end for 6kN capacity, 2 straps for 12kN	All exposure zones
GIB HandiBrac® https://www.gib.co.nz/products/fasteners-and-brackets/gibhandibrac/	All exposure zones
Cyclone Ties (G300 Z275 Galvanised Steel) Nails 30 mm x 3.15 mm in diameter	Exposure zones B & C only
1 x 25-Sheet Brace strap (G300 Z275 Galvanised Steel) Nails 6/ 30 x 3.15 diameter nails per strap end for 6kN capacity, 2 straps for 12kN	Exposure zones B & C only
Mitek angle bracket CPC80 - 1.55, G300, Z275, 16 x 30 mm x 3.15 mm dia. 8/Type 17, 14g x 35 hex head	Exposure zones B & C only
Simpson Strong-Tie DTT2Z - 1.74 mm, G-185, 8 x 6 mm dia x 40 screws, M12 galv. threaded rod, ChemSet	Exposure zones B & C only

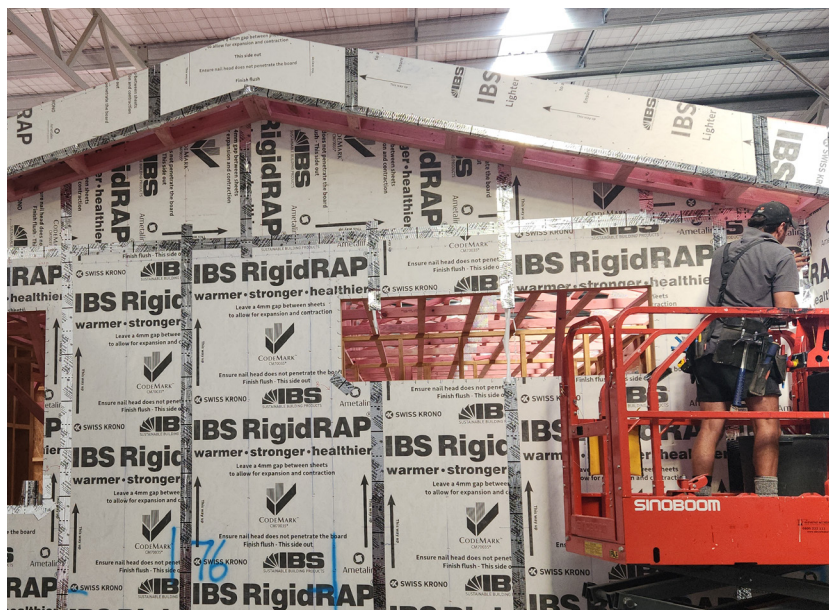

3.14 Bottom Plate Fixing Details

Bottom Plate Fixing Details – Base Detail

Bottom plate detail to concrete or timber floor (with 25 mm x 1 mm strap)

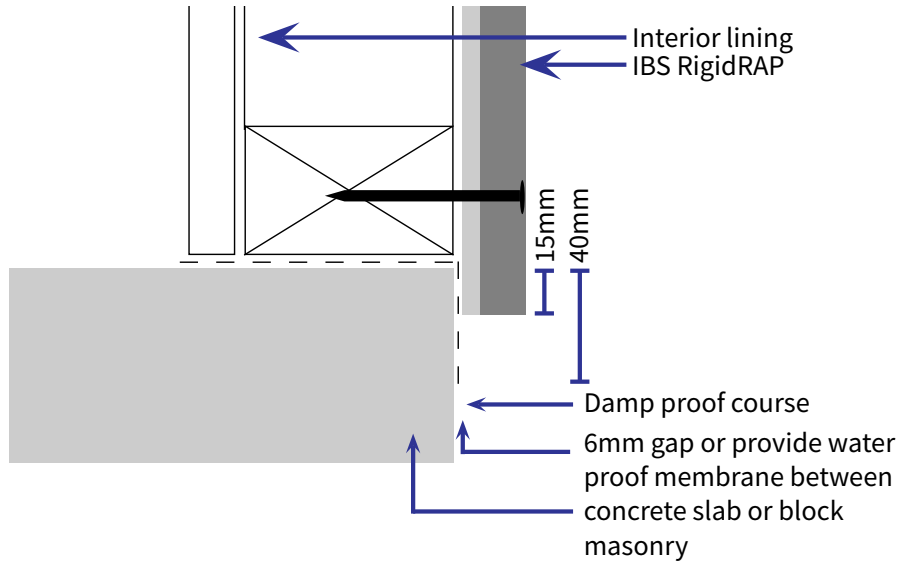

4 or 6 nails per LEG as specified

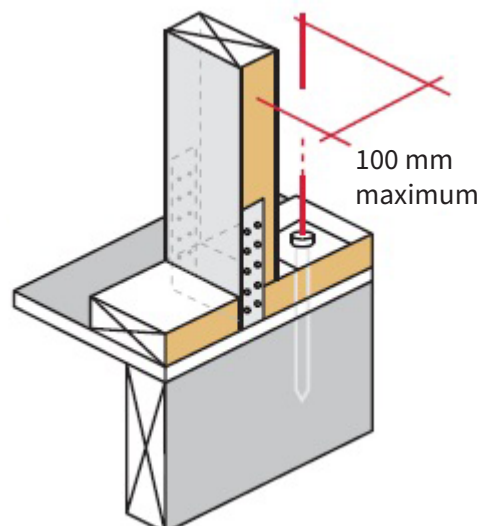
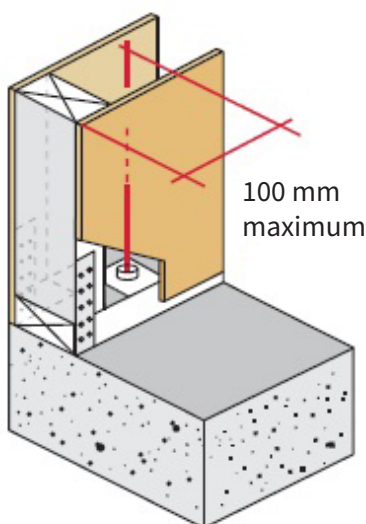
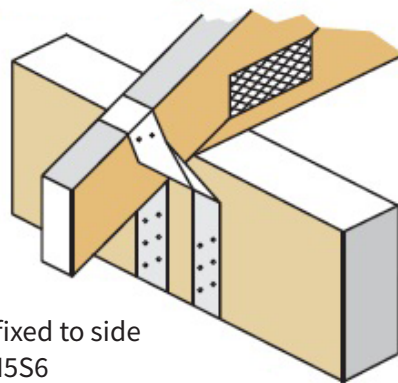

3.15 Hold Down Details

GIB® HandiBrac® Installation – Concrete Floor

Internal walls

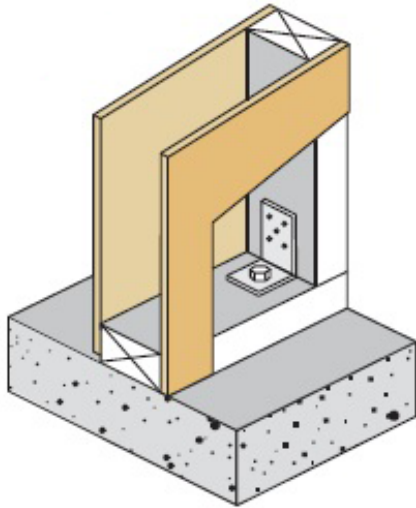

Position GIB® HandiBrac® at the stud / plate junction.

External walls

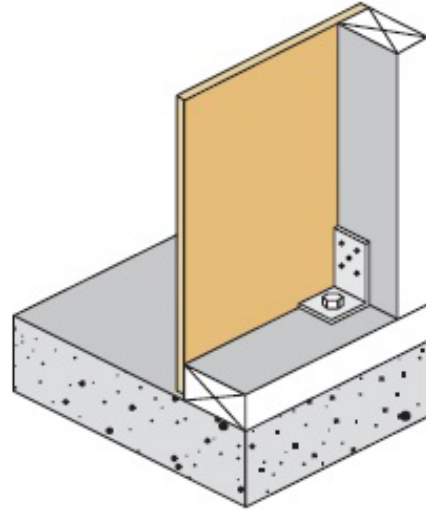

Position GIB® HandiBrac® as close as practicable to the internal edge of the bottom plate.

GIB HandiBrac® Installation – Timber Floor

External walls

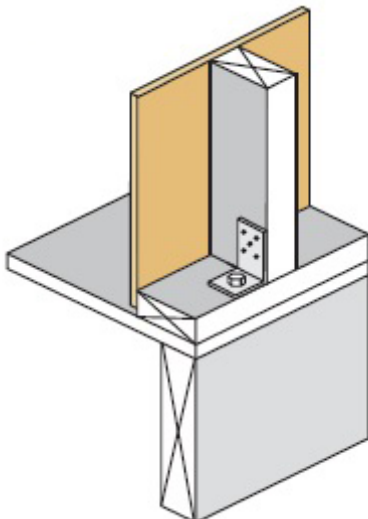

Position GIB® HandiBrac® in the centre of the perimeter joist or bearer.

Internal walls

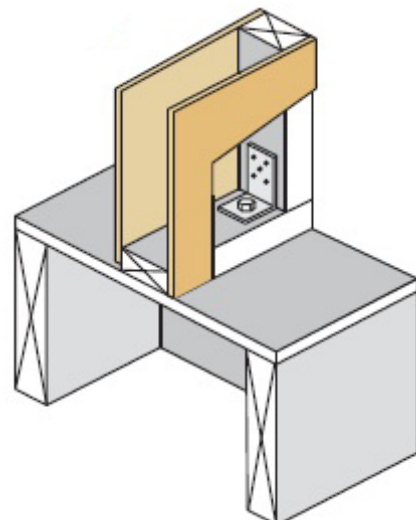

Position GIB® HandiBrac® in the centre of the floor joist or full depth solid block.

4. Joint / Window Sealing & Penetrations

4.1 Recommended Tape Options

See tape supplier information for product limitations.

Approved Joint and Window Tape (minimum face cover 50 mm)	
Thermakraft Premium Joining Tape 75mm x 23m Not to be used as a window flashing.	https://www.thermakraft.co.nz/products/tapes-accessories/premium-joining-tape
3M™ All Weather Flashing Tape 8067	https://www.3mnz.co.nz/3M/en_NZ/p/d/b40068318/
TESCON EXTORA IBS-OS (Pro Clima)	https://proclima.co.nz/tescon-extora/
SUPER-STICK (Marshall Innovations)	https://www.mwnz.com/product/superstick-door-window-flashing-tape
Hydro Tape (masons 75 mm)	https://mpb.co.nz/product/hydro-window-flashing-tape/
Masons 40 Below	https://mpb.co.nz/product/40-below/
Watertight	https://technowrapping.co.nz/watertight-products/
DriStud Cool Tape	https://www.drinspace.co.nz/product/dristud-cool-window-flashing
EUROBAND S 60	https://www.frameprotection.co.nz/
SIGA Wigluv	https://www.siga.swiss/

All tapes are to be installed in accordance with the specific supplier instructions.

All joints and penetrations must be sealed including:

- Vertical and horizontal joints
- External and internal joints
- Penetrations
- Window and door joinery

Vertical joints: 75 mm minimum

Horizontal and sill joints: 150 mm minimum

Where sealing a joint, ensure the IBS RigidRAP® joins are centred under the tape joint.

Use a 25 mm hard PVC roller to ensure full adhesion.

4.2 Installing Service Penetration

Service penetrations must be sealed using a flexible flashing tape. Refer to IBS RigidRAP® approved selection of flexible flashing tapes.

Flashing of pipe and service penetrations must be carried out in accordance with the manufacturers installation guidelines and the following:

- Pipe penetrations through IBS RigidRAP® must have a minimum of 5° slope to the outside
- Flexible flashing tape must be installed like a bandage with a minimum of 25mm cover around the pipe and 100 mm minimum surface adhesion to IBS RigidRAP® panel surrounding the penetration.
- A hole 100 x 100 mm maximum within an envelope of 100mm from top and vertical edges and 200mm from the bottom of the IBS RigidRAP® panel will not affect the bracing capacity. Multiple holes of this size are permitted provided the centre lines of the holes are not closer than 600 mm.
- One hole of up to 400mm by 400mm located between the studs and within the envelope defined above, with nogging framing the hole and fixing of the OSB to the framing as per the requirements for the top and bottom plate is acceptable.

4.3 Installing Window Opening

Refer to IBS RigidRAP® approved selection of flexible flashing tapes. (Section 4)

Flashing window openings must be carried out in accordance with Wanz Guide to E2/ASI (6), substituting building wraps for IBS RigidRAP®.

- Cut the flashing tape for the sill at least 200mm wider than the opening.
- Fit the tape with the inner edge of the tape flush with the inside line of the framing and extend 100mm up and down each jamb edge.
- Ensure the tape is well adhered to the surfaces and fitted tightly to each corner.
- Fully tape all window opening edges.

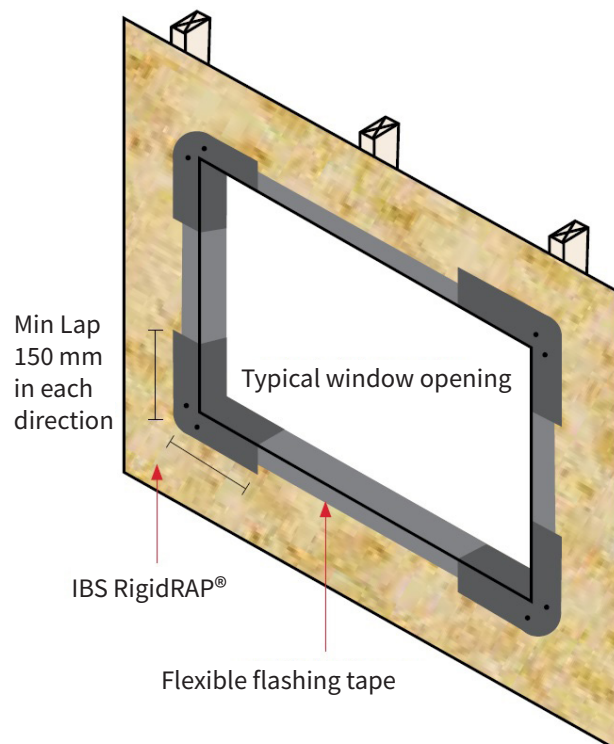

NOTE: All window and joint tapes shall be used in accordance with the manufacturer's installation guide.

5. External Wall Wrap (Rigid Air Barrier)

5.1 Scope of Use

IBS supply IBS RigidRAP® for use in exterior wall construction as an alternative to wall wrap or where a rigid air barrier is required. Applied to the outer face of the exterior framing, IBS RigidRAP® will minimise the pressure difference across the wall construction, thereby forming part of a weathertight external envelope. When installed in accordance with this guide, IBS RigidRAP® performs the function of a rigid air barrier with bracing capacity.

5.2 Non-Structural Rigid Air Barrier (Used as a RAP only)

Scope of Use:

Where RigidRAP® is to be used as a rigid air barrier without a bracing function then the scope of use is increased to include lightweight steel framing provided that a thermal break is installed - in this case, RigidRAP®-XT shall be used.

Panels can be used vertical or horizontal.

IBS RigidRAP® panels shall be nailed off at a maximum of 300 mm centres around the perimeter and through the body of the sheet. Rigidity of the panels will be maximised if the panels are nailed off around the perimeter at 150 mm.

All other installation details to be in accordance with this guide.

The IBS RigidRAP® must be allowed to acclimatise for at least 48 hours prior to installation.

When specifying IBS RigidRAP® as a rigid air barrier, the designer must take into account site specific conditions and the building with respect to, but not limited to, the following:

- Environmental (exposure) zone
- Wind zone
- Wall bracing table for wind and EQ demand
- Structural design loads and framing requirements
- Preparation of substrate
- External envelope
- Other materials likely to affect the performance of IBS RigidRAP®.

6. Temporary Weather Cladding

6.1 Scope of Use

IBS RigidRAP® shall only be used as a rigid air barrier where the cladding system incorporates a ventilated cavity and wall cladding that complies with E2/AS1 or is covered by a relevant CodeMark certificate.

7. Further Information

7.1 What is OSB3?

OSB3 (oriented strand board 3) is a moisture resistant, structural wood panel. Engineered from environmentally sustainable sourced softwood, it consists of three layers of wood strands bonded together with heat-cured adhesives. Each layer is orientated at right angles to the adjacent layer creating a strong, dimensionally stable panel that resists delamination and warping. The absence of natural imperfections such as knots provides certainty of performance.

What makes OSB so strong is due to it being made of three layers, the top and bottom 25% layers are laid running the length of the sheet middle 50% is laid running the width of the sheet. This creates a strong structural panel that is resistant to delamination and warping.

7.2 What is wall underlay?

Wall underlay is a synthetic wall underlay. The product consists of a micro-porous water-resistant polypropylene film laminated between two layers of spunbonded polypropylene.

7.3 IBS RigidRAP® CodeMark explained

IBS is the certificate holder of CodeMark for IBS RigidRAP®. CodeMark is third party certified, allowed for under the Building Act 2004. This means that under law, a Building Consent Authority must accept the specification of IBS RigidRAP® (the panel and the installation details) as complying with the NZ Building Code, providing that all conditions of the certificate have been met.

Achieving CodeMark also focuses on the quality of IBS RigidRAP® panels. This means that designers and installers can use IBS RigidRAP® with confidence that, providing all instructions are followed, IBS RigidRAP® will result in building work complying with the NZ Building Code.

8. Additional Resources

8.1 Compliance and Information

For compliance & information of IBS RigidRAP® refer to:

- IBS Product Specification
- IBS CAD drawings
- IBS Maintenance and Warranty of IBS RigidRAP®
- www.ibs.co.nz
- 0800 367 759

8.2 Available Details

IBS supply further details to assist in the specification of IBS RigidRAP®. These details are available in .dwg, .pdf and .jpg formats. Go to www.ibs.co.nz to download.



9. Limitations

The information contained in this document is current as at April 2024 and is based on data available to IBS Sustainable Building Products at the current time.

All photographic images are intended to provide a general impression only and shall not be relied upon as an accurate example of IBS RigidRAP® products installed in accordance with this document.

IBS reserves the right to change the information contained in this document without prior notice. It is your responsibility to ensure that you have the most up to date information available, including at the time of applying for a building consent. You can call 0800 367 759 or visit www.ibs.co.nz to obtain current information.

IBS has used all reasonable endeavours to ensure the accuracy and reliability of the information contained in this document. However, to the maximum extent permitted by law, IBS assumes no responsibility or liability for any inaccuracies, omissions, or errors in this information nor for any actions taken in reliance on this information.



10. Frequently Asked Questions

Q. How long can IBS RigidRAP be left exposed for?

A. IBS RigidRAP can be left exposed to the weather for up to 90 days.

Q. Do I need to leave an expansion gap between sheets?

A. IBS RigidRAP is designed for a 4mm gap between all sheets vertical and horizontal. (2mm around each sheet)

Q. Do I need to tape all the joins?

A. Yes, all joins vertical and horizontal need to be taped, except mid floor joins as below.

Q. How do you join mid floor sheets?

A. All horizontal mid floor joins need to have a Z flashing or 150mm Tape.

Q. Can I wrap another building wrap around the board instead of taping joins?

A. No, as the board and wrap are tested as a system.

Q. Can I use IBS RigidRAP on steel frames?

A. No, for steel frames you need to use IBS RigidRAP-XT as you need a thermal break.

Q. Do nails and screws need to have tape on them?

A. No, you do not need to tape over them unless they penetrate the board. All fixings shall finish flush with the board.

Q. Can IBS RigidRAP be used as bracing?

A. Yes, IBS RigidRAP has been tested as a bracing element. Details are listed in this installation guide.

Q. Do I need to install sheets vertically?

A. Yes, when used as a bracing element, all sheets need to be installed vertically. Writing can be upside down.

Q. Can I use RigidRAP as a wrap only?

A. If using IBS RigidRAP as non bracing, sheets can be installed vertically or horizontally. You can nail off at 300 mm centres around the board.

11. Installation checklist

The below installation areas are considered critical to the successful installation of IBS RigidRAP®. Using this sheet as a checklist during installation will aid in problem free product installation and long term product durability post construction.

Task	X when checked
Prior to Specification and Installation	
Read the IBS RigidRAP® Installation Guide & have a hard copy on site	<input type="checkbox"/>
Health and Safety	
Take all steps to ensure your safety and the safety of others (adequate ventilation and protection)	<input type="checkbox"/>
Ensure IBS RigidRAP® is well supported when cutting or drilling the panel	
Install	
IBS RigidRAP® panels with the polypropylene film laminated facing outwards	<input type="checkbox"/>
Ensure clean-cut edges with sharp tools, using a backing block to minimize break out	
Joint Sealing and Window Tape	
Use an approved flashing tape in accordance with the specific supplier instructions (page 35)	<input type="checkbox"/>
Ensure the IBS RigidRAP® joins are centred under the tape joint (all joints and penetrations must be sealed)	<input type="checkbox"/>
Service Penetration	
Service penetrations must be sealed using a flexible flashing tape	<input type="checkbox"/>
Pipe penetrations through IBS RigidRAP® must have a minimum of 5° slope to the outside	<input type="checkbox"/>
Minimum of 25mm cover around the pipe and 100 mm minimum surface adhesion to IBS RigidRAP® panel surrounding the penetration	<input type="checkbox"/>
Window Opening	
Flashing window openings must be carried out in accordance with Wanz Guide to E2/ASI (6)	<input type="checkbox"/>
Bracing Capacity	
IBS RigidRAP® may be used as a bracing element within the required scopes detailed in the IBS RigidRAP® Installation Guide (table 1, page 7)	<input type="checkbox"/>
Installation must be in accordance with the instructions in the IBS RigidRAP® Installation Guide (for all bracing systems, no product substitution is allowed)	<input type="checkbox"/>
Handling and Storage	
Ensure correct storage and handling in transport for the protection of IBS RigidRAP®	<input type="checkbox"/>
Finishing	
A 20 mm ventilated cavity and the cladding/joinery system must be installed so that it complies with the NZ Building Code.	<input type="checkbox"/>



IBS RigidRAP®

Design & Installation Guide



Scan the QR code to view
all IBS RigidRAP® documents.

3 Zelanian Drive, East Tamaki
Auckland, New Zealand 2013

General Inquiries:

☎ 0800 367 759

✉ info@ibs.co.nz

🌐 www.ibs.co.nz