

# IBS Showerline

## Wetwall Lining

### Design & Installation Guide

November 2025

CodeMark

CMNZ70192



**BUILDING BETTER HOMES**

Proudly Kiwi Owned and  
Operated for over 30 years





## SUSTAINABLE BUILDING PRODUCTS

*Welcome to Independent Building Supplies (IBS), your trusted partner in the New Zealand building industry. Since our inception in 1993, IBS has been dedicated to sourcing and providing the highest quality building materials from around the globe. As a family business with four generations active in the building industry in New Zealand, we bring a wealth of experience and a deep commitment to excellence.*

One of the key aspects that set IBS apart is our commitment to innovation. We are constantly on the lookout for new and improved building materials that can enhance the efficiency and effectiveness of construction projects. Our team of experts works closely with suppliers to bring cutting-edge products to the New Zealand market, ensuring that our customers have access to the latest advancements in building technology.

But our commitment to excellence doesn't stop at our products. At IBS, we pride ourselves on providing unparalleled customer service. Our knowledgeable and friendly team is always on hand to offer expert advice and support, helping you choose the right materials for your project.

### ABOUT **IBS**

At IBS, we recognise that the foundation of any great building project lies in the quality of the materials used. That's why we meticulously select our suppliers, ensuring that every product meets our stringent standards for durability, performance, and sustainability. Our extensive range of offerings includes everything from plywood and panels to flooring and cladding, all tailored to meet the diverse needs of the New Zealand market.





*We seek to develop the most innovative, professional and profitable experience for our clients.  
Our passion is for providing our customers with the best products, the best service, and the best experience*

In addition to our exceptional product range and customer service, IBS is also dedicated to sustainability. We recognise the importance of protecting our environment and are committed to sourcing eco-friendly building materials. Our sustainable product offerings help reduce the environmental impact of construction projects, allowing our customers to build responsibly without compromising on quality or performance.

IBS is more than just a supplier of building materials; we are a partner in your success. Our comprehensive range of services includes everything from product sourcing and logistics to technical support and training. We work closely with our customers to understand their unique needs and provide tailored solutions that help them achieve their objectives.

Join the countless builders, contractors, and homeowners who trust IBS for their building material needs. Discover the difference that quality, innovation, and exceptional service can make in your next project. Choose Independent Building Supplies – your partner in building excellence for over 30 years.

- IBS RigidRAP®
- IBS RigidRAP®- XT
- IBS EUROFloor
- IBS EUROLine
- IBS FIBRE® Range
- IBS Structural Ply
- IBS Builders Grade® Ply
- IBS Formply

- IBS Decorative Ply
- IBS PanelLine®
- IBS Showerline
- IBS Softboard
- IBS Hardboard
- IBS Peg Board
- IBS Acoustic Panels
- IBS Mini Panels

# Contents

---

<b>1.</b>	<b>Introduction</b>	<b>6</b>
1.1	Introduction	6
1.2	Scope	6
1.3	Sizes & Applications	6
1.4	Benefits	6
1.5	Codemark	7
1.6	Supporting Info & Documents	7
<b>2.</b>	<b>Best Practice</b>	<b>8</b>
2.1	Health & Safety	8
2.2	Handling & Storage	8
2.3	Cutting	9
2.4	Trimming Sheets	9
2.5	Drilling	9
<b>3.</b>	<b>Durability</b>	<b>10</b>
3.1	Compliance	10
3.2	Responsibility	10
3.3	Conditions	11
3.4	Defects	11
3.5	Differing Installation	11
3.6	Prohibited Uses	11
<b>4.</b>	<b>Design</b>	<b>12</b>
4.1	Check the Substrate	12
4.2	Framing	12
4.3	Frame Tolerances	12
4.4	Timber	12
4.5	Steel	13

<b>5.</b>	<b>Installation</b>	<b>14</b>
5.1	Fixing IBS Showerline	14
5.2	Ceiling Installation	15
5.3	Wall Assembly	16
5.4	Wet Area Installation & Sealing	19
5.5	IBS Showerline Vinyl Floor Junction	20
5.6	Heated Towel Rail on IBS Showerline	21
5.7	IBS Showerline as Kitchen Splashback	22
5.8	Creating Openings	23
5.9	Trimmings and Mouldings	26
5.10	Silicone Joints	36
5.11	Wall to Ceiling joint	37
5.12	Wet Area Wall Joints	37
5.13	Around Baths and Showers	40
5.14	Stainless Steel Shower Tray	43
<b>6.</b>	<b>Finishing</b>	<b>44</b>
6.1	Removing Protective Layer	44
6.2	Cleaning IBS Showerline Panels	44
<b>7.</b>	<b>Care, Maintenance</b>	<b>45</b>
<b>8.</b>	<b>Warranty</b>	<b>46</b>
<b>9.</b>	<b>Technical Properties</b>	<b>49</b>
<b>10.</b>	<b>Additional Resources</b>	<b>50</b>
<b>11.</b>	<b>Frequently Asked Questions</b>	<b>51</b>
<b>12.</b>	<b>Limitations</b>	<b>53</b>
<b>13.</b>	<b>Installation Checklist</b>	<b>54</b>

NZBN 9429000097253

**Contact us for more information or to talk to our team.**

[www.ibs.co.nz](http://www.ibs.co.nz) | 0800 367 759 | [info@ibs.co.nz](mailto:info@ibs.co.nz)

# 1. Introduction

---

## 1.1 Introduction

IBS Showerline is the ideal choice for all wet wall lining requirements. It is impact resistant and has a soft-look white curtain coated finish that is easy to keep clean. This will mean that your wet or utility area will stay looking great for many years to come.

Importantly, it is simple to install. Due to the nature of the product, IBS Showerline can be directly fixed to framing as well as fixed over the top of most other substrates. The following installation guide offers basic recommendations for interior applications.

## 1.2 Scope

The scope of this specification pertains to the use of IBS Showerline, applicable to buildings that meet the limitations set forth in the New Zealand Building Code (NZBC). This manual addresses the use of IBS Showerline for construction methods, including direct fixing or cavity installations.

This document is intended for use by architects, builders, designers involved in the specification of IBS Showerline.

## 1.3 Sizes & Applications

TABLE 1 - IBS Showerline Product Details			
L x W x Thickness (mm)	Weight (kg)	IBS Product Code	GTIN
2400 x 900 x 4.75	11.9	SLINEP04249	09421028761116
2400 x 1200 x 4.75	15.8	SLINEP042412	09421028761109

## 1.4 Benefits

- **Strength and Durability:** IBS Showerline is an aluminium composite panel comprising a PE (polyethylene) core sandwiched between layers of 0.4 mm aluminium, providing exceptional strength and durability.
- **Impact Resistant:** The panel is impact resistant, making it ideal for high-traffic areas and ensuring long-lasting performance.
- **Smooth and Stylish Finish:** The soft-look white curtain-coated finish is not only stylish but also easy to keep clean, maintaining its visual appeal over time.
- **Waterproof and Mould Resistant:** IBS Showerline is waterproof and mould resistant, making it perfect for wet areas such as bathrooms, kitchens, and laundries.

- **Easy to Clean:** The panel is easy to clean with a simple solution of 5% detergent and warm water. Avoid using steel wool or abrasive cleaning products, such as cream cleaners, commercial grade cleaners or harsh chemicals.
- **Grout Free:** Enjoy a seamless and grout-free finish that enhances the aesthetic appeal of your space.
- **Easy to Install:** IBS Showerline is designed for easy installation, saving you time and effort.
- **Consistent Colour:** The curtain-coated finish ensures consistent colour, providing a flawless and cohesive appearance.

#### Intended Use

- Bathrooms
- Kitchens
- Laundries
- Food Preparation Areas
- Ceiling Lining
- Any other areas where easy clean-up is required

**Note:** IBS Showerline ACP is a conductive panel and may require earthing if used near any power sockets, switches, or light fittings. Consult a registered electrician.

### 1.5 Codemark

IBS is the certificate holder of CodeMark for IBS Showerline. CodeMark is third party certified, allowed for under the Building Act 2004.

A CodeMark certification offers several key benefits:

- **Streamlined Approval Process:** Building Consent Authorities must accept CodeMark-certified products as compliant with the NZ Building Code, simplifying the building consent process.
- **Quality Assurance:** CodeMark certification is a consistent and objective measure of quality, ensuring that products meet high standards.
- **Reduced Risk:** Using CodeMark-certified products reduces the risk of defects and installation issues, as these products are thoroughly assessed and verified.
- **Confidence:** It provides confidence to designers, builders, and consumers that the products will perform as expected and comply with regulatory requirements.

### 1.6 Supporting Info & Documents

This document must be read in conjunction with the:

- IBS Showerline Product Specification
- IBS Showerline Wetwall Lining Warranty.

All other information including any updates is available at [www.ibs.co.nz](http://www.ibs.co.nz).

# 2. Best Practice

---

## 2.1 Health & Safety

Take all necessary steps to ensure your safety and the safety of others:

- Ensure adequate ventilation or mechanical dust extraction when cutting or drilling.
- Ensure the IBS Showerline sheets are well supported when cutting
- Wear appropriate safety equipment, clothing and footwear.
- Use all tools in accordance with relevant instruction manuals.
- Clear the work area of any obstructions before work starts.

### **For further information refer to:**

WorkSafe Small Construction Sites, The Absolutely Essential Health and Safety Toolkit.

WorkSafe Health and Safety at Work, Quick Reference Guide.

## 2.2 Handling & Storage

### **Loading and Unloading**

Take care when transporting, handling, and unloading IBS Showerline sheets to avoid damaging the sheets. If unloading manually, carry the sheets on their edge to prevent bending or warping.

If unloading mechanically, ensure there are at least two well-spaced supports or use a pallet to prevent excessive bending or sagging of the sheets. When using a crane, a spreader bar may be required to ensure the sheets are lifted evenly and safely.

### **Transport to Site**

The dunnage strapped to the bottom of the packet is intended for transport purposes only and is not suitable for on-site storage. Ensure that the sheets are secured properly during transport to prevent any shifting or damage. Use proper equipment to load and secure the sheets to avoid any unnecessary pressure or impact.

### **Storage**

Store IBS Showerline sheets in a dry, clean area, keeping them flat and off the ground to prevent damage. Protect them from dust and debris to maintain their grout-free, waterproof, and mould-resistant properties. Proper storage ensures the panels stay in top condition for easy installation and long-lasting use in wet areas like bathrooms and kitchens.

The storage area should be dry, well-ventilated, and out of direct sunlight to avoid any potential degradation of the material or finish. Proper storage conditions help maintain the quality and longevity of the sheets until they are ready for installation.

Before installation please check panels for defects.

### **Site considerations:**

## **2.3 Cutting**

Cut IBS Showerline sheets using standard wood working tools like a table saw or circular saw with a fine-tooth blade (60 tooth or higher) to provide a clean, smooth cut. Apply painter's tape to the line of cut to minimise chip out and to protect the sheet surface. A fine tooth handsaw may also be used.

When small amounts of cutting are required on site, an alternative to the recommended saw blade is a carbide-tipped flat trapezoidal tooth blade. This has limited life and will need regular changing.

## **2.4 Trimming Sheets**

PVC or aluminium trims may be used for internal and external corners, junctions to fittings or fixtures and as a finish to edges.

## **2.5 Drilling**

Drilling IBS Showerline requires careful attention to detail to ensure a clean and precise finish. First and foremost, it is essential to use the right tools and safety equipment. Ensure that you have adequate ventilation or mechanical dust extraction when cutting or drilling the Showerline panels. The panels should be well-supported to prevent any bending or sagging during the drilling process.

Wearing appropriate safety gear, such as gloves, safety glasses, and a dust mask, is crucial to protect yourself from any debris generated. Additionally, using sharp, high-quality drill bits designed for aluminium composite panels will help achieve a clean cut without damaging the material.

When drilling, it is recommended to start with a smaller pilot hole before moving to the desired hole size. This approach helps in maintaining accuracy and prevents the material from chipping. It is also important to drill at a slow and steady pace, applying consistent pressure to avoid overheating the drill bit and the panel.

If you need to create larger openings, such as for plumbing or electrical fixtures, it is advisable to use a hole saw with a fine-toothed blade. After drilling, always clean the edges of the holes to remove any burrs or sharp edges, ensuring a smooth and safe finish.

# 3. Durability

---

## 3.1 Compliance

IBS Showerline Wetwall Lining complies with the New Zealand Building Code when installed, and maintained according to IBS requirements.

The compliance process for IBS Showerline Wetwall Lining with the New Zealand Building Code involves several key steps to ensure that the product meets all necessary standards and regulations.

IBS Showerline Wetwall Lining is an aluminium composite panel with a polyethylene (PE) coating, which makes it suitable for use in various wet areas such as bathrooms, kitchens, and laundries. The product has been tested and demonstrated to comply with several clauses of the New Zealand Building Code, including B1 Structure, B2 Durability, E3 Internal Moisture, F2 Hazardous Building Materials, and G3 Food Preparation and Prevention of Contamination.

Additionally, the compliance process involves ensuring that the product is used in conjunction with a primary structure that complies with the New Zealand Building Code or where the designer and/or installer has determined that the existing structure is suitable for the intended building work.

The product must also be earthed when electrical outlets, light switches, fittings, etc., are installed in the panel or wires are run behind it.

### To Minimise Risk:

Whenever possible, use cutting tools that are equipped with dust extraction or suppression features. Ensure the work area is properly ventilated and protect yourself from dust exposure by wearing appropriate personal protective equipment, including safety goggles, protective clothing, and a certified respirator, such as a P2 dust mask.

For further safety details, please refer to the relevant Product Data Sheet, available upon request.

## 3.2 Responsibility

Designers and/or contractors responsible for the intended project should follow the details and recommendations specified in this manual.

It is also wise to keep in mind that all designs and constructions should comply with appropriate and relevant requirements of current legal building codes, regulations and standards, both domestic and international.

\*The information provided in this installation guideline is valid at the time of publication.

### **3.3 Conditions**

- IBS Showerline panels should be installed at least 300mm away from any open gas flame and 100mm from any electrical heat source.
- Ensure the existing substrate is level using a straight edge and is not out of level by more than 1mm over 1 metre length.
- Ensure the substrate is clean, dry, and free from dust or debris before installation.
- Direct fixing to concrete or concrete masonry is not recommended.
- Only use warm soapy water with a soft cloth to clean. Do not use commercial grade chemicals or cream cleaners to clean.
- Where power points, switches, light fittings, or wiring are present, the sheet must be earthed.

### **3.4 Defects**

Before Installation, please ensure you check the panels for defects or damage.

### **3.5 Differing Installation**

To ensure the warranty on the product remains valid, it is crucial to follow the design and installation guidelines provided. Failure to adhere to these instructions may result in the warranty being voided.

### **3.6 Prohibited Uses**

Specifiers, designers and installers must ensure that any time IBS Showerline is installed it is only used when all conditions are met in relation to the local requirements as well as E2/AS1 and the current Building Code.

# 4. Design

---

## 4.1 Check the Substrate

IBS Showerline may be fixed to most substrates, and directly to framing. Direct fixing to concrete or concrete masonry is not recommended. Timber battens or an overlay of suitable substrate is necessary for installations over DPC. Check the substrate is level and true.

Ensure all surfaces are clean, dry, smooth and free from dust, grease, solvent, wax. Lightly sand glossy surfaces to remove sheen.

## 4.2 Framing

In order to achieve an acceptable wall finish, it is imperative that framing is straight and true. Framing tolerances must comply with the requirements of NZS 3604. All framing shall be made flush and can be installed vertically or horizontally.

Ensure adequate framing support to all edges and where penetrations are made for plumbing fixtures. Where IBS Showerline sheets are to be glued directly to timber framing, check that the moisture content of the timber is no more than 18%.

## 4.3 Frame Tolerances

Make sure the frame is square and start from a central datum line. The frames should be straight and level to ensure a flush surface for the sheeting.

For optimal results, it is recommended to maintain a maximum tolerance of 3mm to 4mm over any 3000mm length of the frame. IBS Showerline will not correct frames that are excessively warped or distorted, and any warping may remain visible after the internal lining is installed.

## 4.4 Timber

Timber framing must meet at least the requirements set out in NZS 3604, “Timber Framed Buildings.” Additionally, the treatment and moisture content of the timber framing must comply with NZS 3602 standards.



**Figure 1**  
Timber batten



**Figure 2**  
Metal stud

## 4.5 Steel

The minimum size for steel stud framing should be 64mm deep by 35mm wide, with a minimum base metal thickness (BMT) of 0.55mm.

Steel framing must meet the minimum stiffness requirements outlined in NZS 3604. For additional guidance on steel framing, refer to the NASH 3405 document or consult your steel framing supplier.

Steel sections should be appropriately galvanized / zinc-coated to meet the durability requirements of the NZBC. Consult the framing manufacturer for more information.

### Electrical Earthing

IBS Showerline has an aluminium face, which is conductive to electricity. In situations where there is any kind of power point, switch, light fitting or wire running behind the sheet, an earth connection must be made.

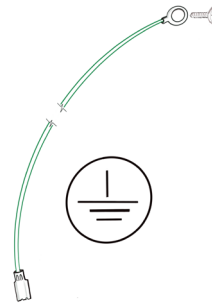

**Figure 3**  
Earthing (ground) Strap

### Important Safety Message:

IBS recommends using a crimp lug (a simple screw connector) that connects to a bonding wire which runs down the back of the sheets. IBS recommends that the installation of the earthing be carried out by a registered electrician. As a minimum a registered electrician should confirm that the earthing has been correctly installed.



# 5. Installation

---

## 5.1 Fixing IBS Showerline

IBS Showerline may be fixed to most substrates, and directly to framing. Direct fixing to concrete or concrete masonry is not allowed. Timber battens or an overlay of suitable substrate is necessary for installations over DPC.

Check the substrate is level and true. Ensure all surfaces are clean, dry, smooth and free from dust, grease, solvent, wax. Lightly sand glossy surfaces to remove sheen.

### **Gluing**

Wipe the back surface of the IBS Showerline sheet with a damp cloth.

If installing over an existing substrate or directly to framing you may apply double-sided foam tape to the back of the sheet around the perimeter to hold the panel while awaiting the adhesive to cure.

### **Protective Coating**

The protective coating layer should be removed from the panels as soon as the adhesive has cured, no more than 24 hours after installation. However, around the edges, the protective layer will need to be partially removed for the installation of trims.

### **Dry Layout**

Complete a dry layout prior to applying any adhesive. A dry layout is important to ensure that the final placement of the IBS Showerline sheets is square and true. It will highlight if adjustments are needed to walls or if sheets need to be trimmed to accommodate wall, floor or ceiling alignment.

Take account of placement and sheet size to ensure the sheet joins meet on a stud if applying to framing. When completing the dry layout ensure that the sheets are installed vertically, i.e., not sideways.

Ensure allowances are made for trim installation. Always install in the same direction vertically, i.e. not upside down. See writing on the protective layer to ensure the correct orientation.

## Recommended Adhesives and Sealants

TABLE 2 - IBS Showerline recommended Adhesives and Sealants			
Glue	Sealant	Preparation	Tape
Sika® Flex-123 MS Bond	Sikasil® NG Sealant	Sika® Aktivator-205	Gator Double Sided Tape
Sika® Nailbond Premium	Bostik MS Safe Sealant	Bostik Ultra NP Primer	
Soudal Fix All High Tack	Bostik Kitchen & Bathroom Silicone		
	Soudal Gorilla Bathroom & Kitchen		
	Soudal Gorilla MS Sealant		
	Selleys Wet Area Sealant		

Other adhesives or sealants may be used provided you have confirmed they are suitable for installing this product in accordance with the manufacturer’s recommendations from the adhesive or sealant supplier. It is essential that any product selected is flexible to accommodate minor movement in the installation.

### 5.2 Ceiling Installation

IBS Showerline may be used as a ceiling lining in most situations but is a great ceiling lining when used in a wet area room such as a toilet, bathroom, laundry, kitchen or anywhere you want a great prefinished ceiling that is easy to keep clean.

Check the substrate is level and true and ensure that all surfaces are clean, dry, smooth, and free from dust, grease, solvent, or wax.

Check that the timber ceiling strapping has a moisture content of no more than 18% prior to installation. Ceiling strapping centres are recommended at 400mm but can be up to a maximum of 450 centres.

Wipe the back of the IBS Showerline sheet with a wet cloth prior to installation and allow to dry. Tape must be used to support the IBS Showerline sheets as an interim measure while awaiting the adhesive to cure. Use Gator double-sided tape or equivalent.

Peel back the edges of the face protective covering by at least 50mm to make it easier to remove 24 hours after installation and to allow for the installation of mouldings.

Apply the tape to all strapping surfaces. Apply a 5mm bead of adhesive to all contact points with the strapping. Press the sheet in place and apply pressure evenly across the sheet. Make sure that you also support the sheet while the glue cures with temporary propping.

Ensure that any props are protected with a soft covering so that there is no damage to the sheet surface. Remove any excess adhesive while it is still wet using a damp cloth.

See Figure 3 on page 13 for electrical earthing instructions for any sheets with light fittings.

### 5.3 Wall Assembly

Ensure adequate framing support to all edges and where penetrations are made for plumbing fixtures. Where IBS Showerline sheets are to be glued directly to timber framing, check that the moisture content of the timber is no more than 18%.

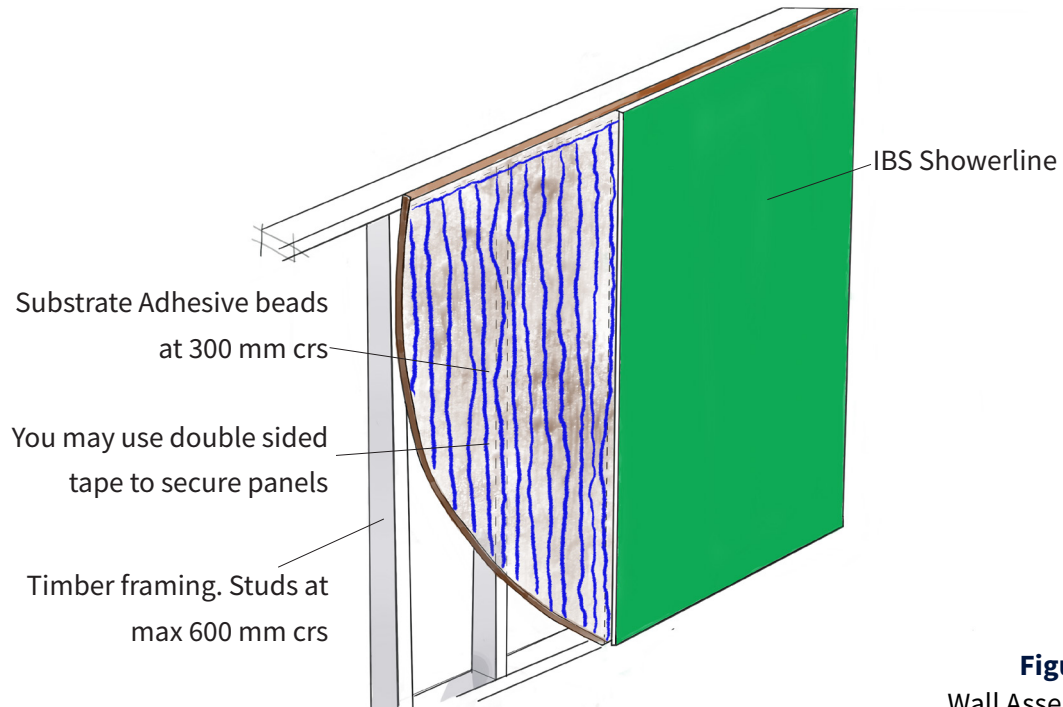

**Figure 4**  
Wall Assembly

#### Important note:

- IBS Showerline panels must be installed a minimum of 100mm away from any electric heat source and 300mm from any gas heat source.
- Cover the sheets.
- The dunnage strapped to the bottom of the packet is for transport only and is not suitable to be used for on-site storage.
- Ensure the area where the IBS Showerline is stored is dry, well-ventilated, and out of direct sunlight.
- Earth the sheets if there is a power or light outlet on the sheet.
- Sheets may be installed directly to the studs.

### Adhesive fixing detail

Apply 15mm diameter adhesive daubs at 200mm intervals on stud and nogs, or alternatively, use a continuous 6mm adhesive bead.

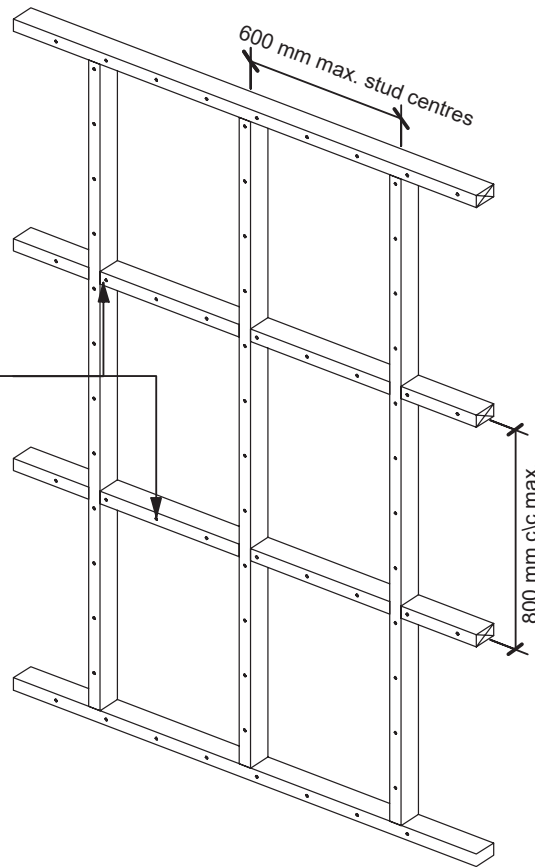

Figure 5

### Fixing to walls tape and adhesive method

Minimum two rows of equally spaced nogs in a 2400mm high wall

Apply 15mm diameter adhesive daubs at 200mm intervals on stud and nogs, or alternatively, use a continuous 6mm adhesive bead.

Apply double-sided tape to both the upper and lower frames to help hold the board in place while the glue cures.

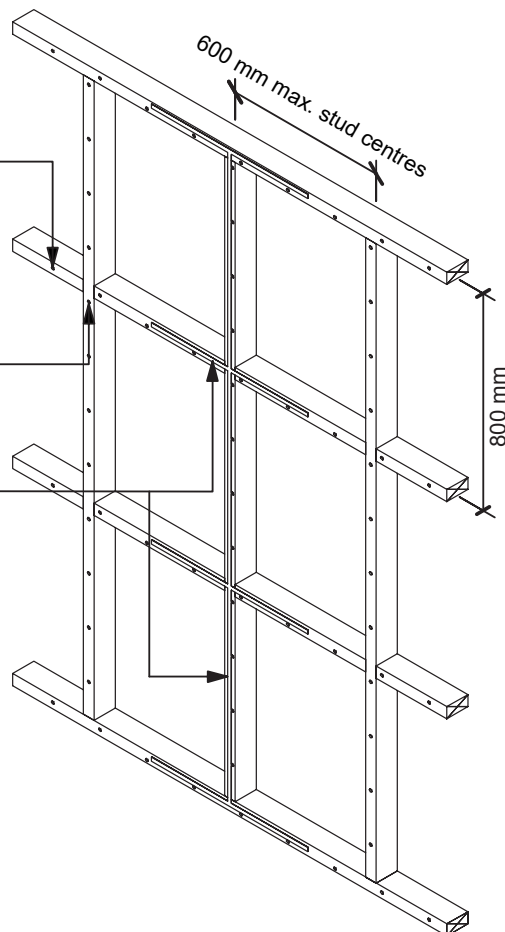

Figure 6

## Fixing to walls fixing and adhesive

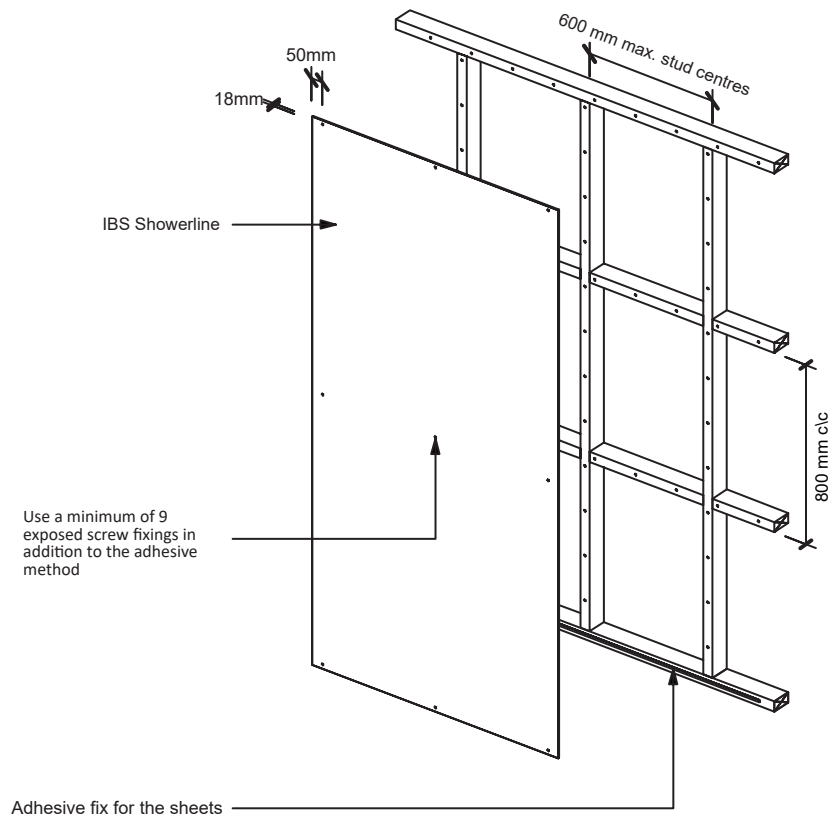

Figure 7

## Fixing to walls with existing substrate

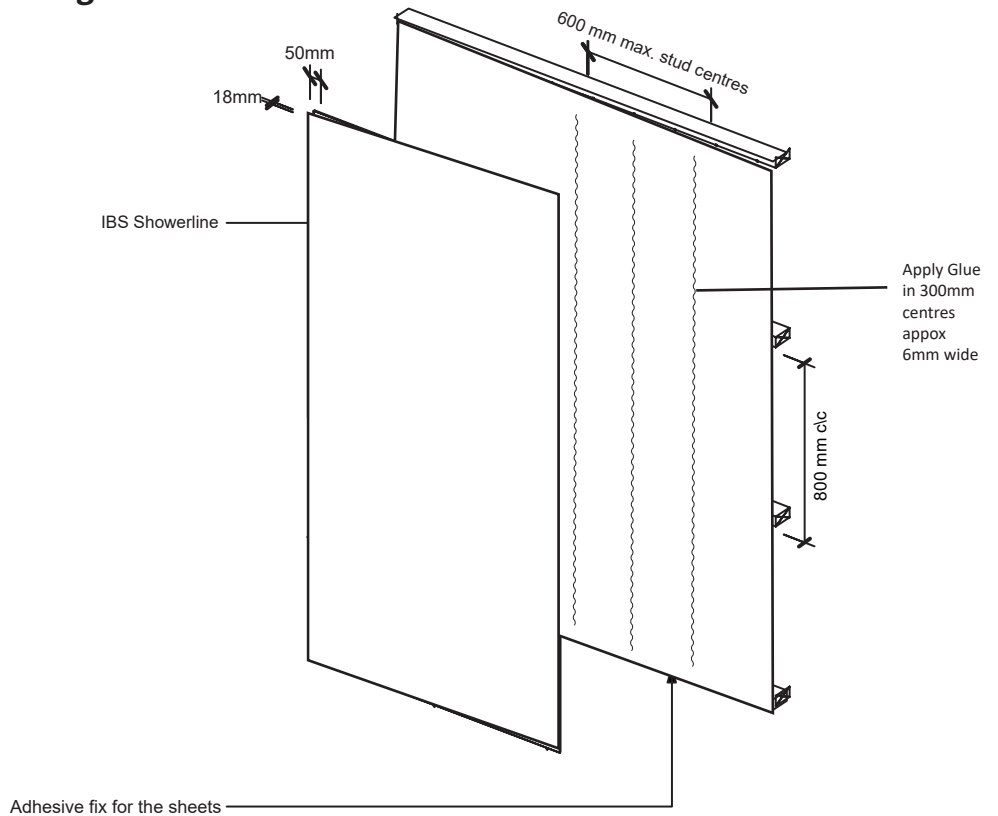

Figure 7a

## 5.4 Wet Area Installation & Sealing

### Shower Trays

Overlap the top edge of the shower tray, while maintaining an open gap of approximately 5.0 mm (anti-capillary) between the edge of the shower tray and the sheet. Apply a bead of silicone/sealant to the upper edge of the tray lip or flange before the sheet is installed

### Bath or Basin Edge

Most new baths or basins come complete with a raised lip or flange on the top edge. Overlap the lip or flange, while maintaining an open gap of approximately 5.0 mm (anti-capillary). Apply a bead of silicone/sealant to the upper edge of the lip or flange before the sheet is installed.

If your bath does not have either a raised lip or flange, a proprietary flashing is the simplest solution to waterproof these junctions. Ensure the flashing has sufficient cover over the fixture edge.

### Sealing Wet Area

Apply a thin bead (2.0 mm - 3.0 mm) of sealant to the connecting edge of each sheet on both vertical and horizontal edge profiles. Apply a thin bead of sealant along cut edges or edges placed in corners, if not using trims. Apply sealant in the trim channel if corner trims are used. Where possible remove excess silicone/sealant before it cures.



## 5.5 IBS Showerline Vinyl Floor Junction

### Junction Details:

- The specified drip edge of the IBS Showerline panel extends 75mm, which exceeds the 25mm requirement, providing additional water resistance.
- The vinyl cove extends 175mm, beyond the required 100mm, further enhancing the waterproofing performance.
- Use of flexible sealant to vinyl and IBS Showerline junction.
- A 100mm upstand is included, doubling the 50mm requirement as per figure 8.

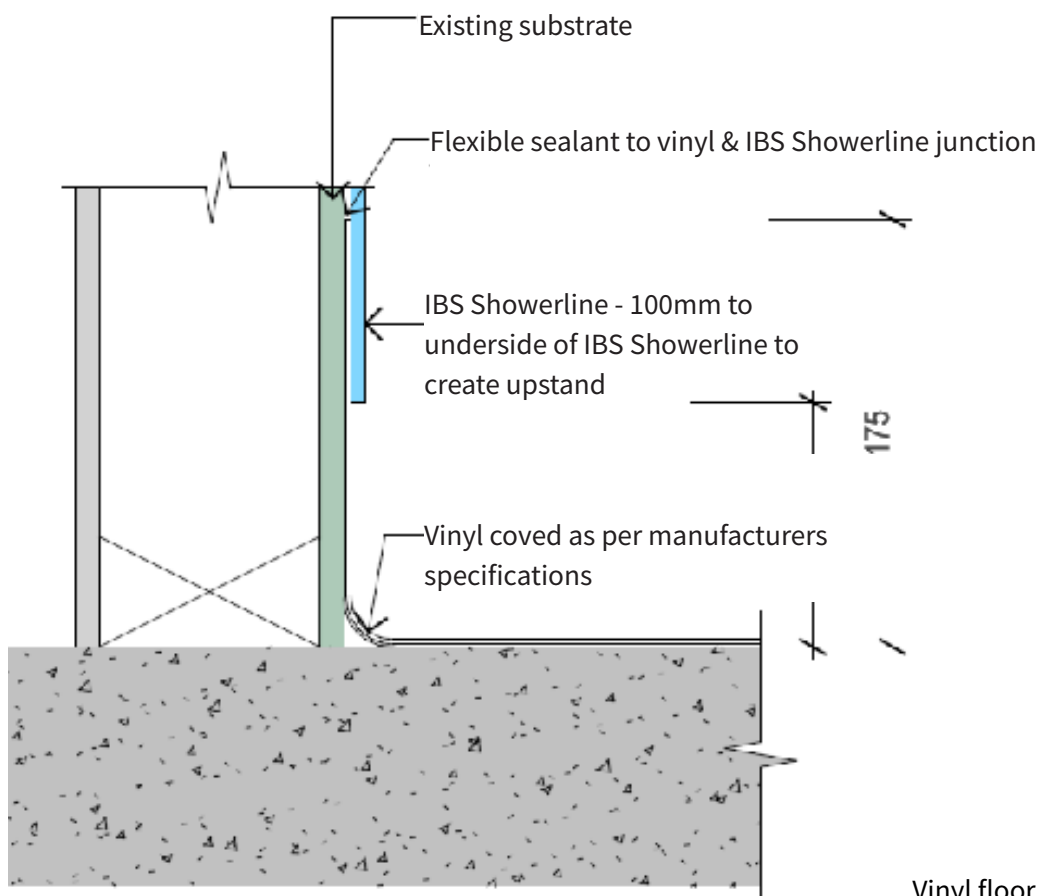

**Figure 8**

Vinyl floor junction

This enhanced configuration should provide a robust barrier, significantly reducing the likelihood of water contact with either the existing substrate or the timber wall.

Based on these improvements, we confirm that this installation detail meets our quality and performance standards for use of IBS Showerline and should provide an effective solution for vinyl flooring junctions in shower areas.

## 5.6 Heated Towel Rail on IBS Showerline

### Offers enhanced waterproofing with key features:

- Installing a heated towel rail onto a sheet of IBS Showerline requires careful planning and the right tools to ensure a secure and professional finish.
- Begin by selecting the desired position for the towel rail, considering both the height and proximity to the power source.
- Mark the positions of the mounting brackets on the IBS Showerline panel, ensuring they are level and evenly spaced.
- Use a stud finder to locate any studs behind the panel; if there are no studs, you will need to use appropriate wall anchors to secure the brackets.
- Drill pilot holes at the marked positions, taking care to use a drill bit suitable for aluminium composite panels to avoid damaging the IBS Showerline.
- Once the pilot holes are drilled, attach the mounting brackets to the IBS Showerline panel using screws and wall anchors if necessary. Ensure the brackets are securely fastened and level before proceeding.
- Next, align the heated towel rail with the brackets and attach it using the provided screws or fixings.
- If the towel rail is electric, carefully route the power cable through the panel and connect it to the power source, ensuring all electrical work complies with local regulations and safety standards.
- An earthing lug should be connected to the IBS Showerline sheet.

## 5.7 IBS Showerline as Kitchen Splashback

IBS Showerline can be used as a splashback.

Minimum clearance of 300mm must be maintained from the closest outer ring of gas hob.

Minimum clearance of 100mm must be maintained from the closest outer ring of electrical element.

### Electric Hob

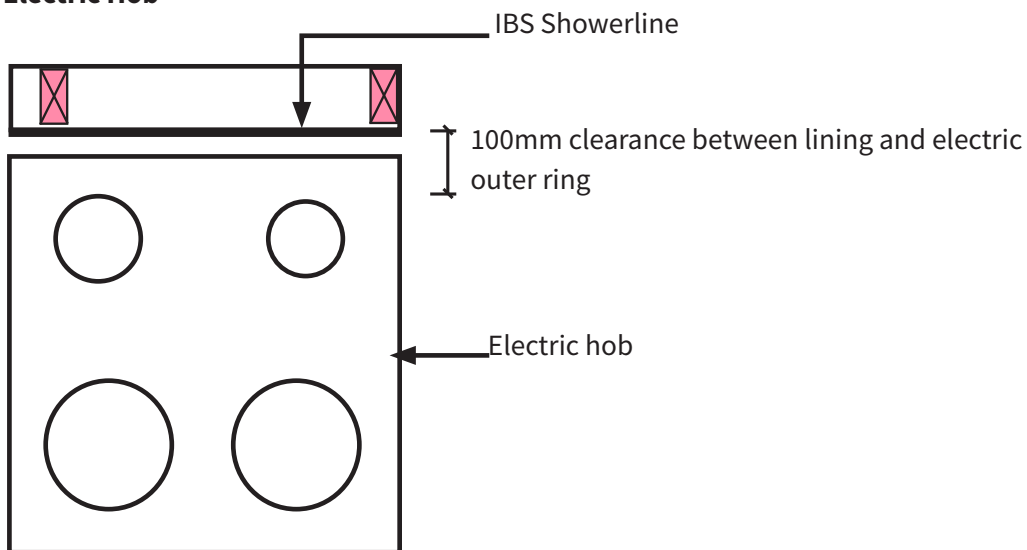

### Gas Hob

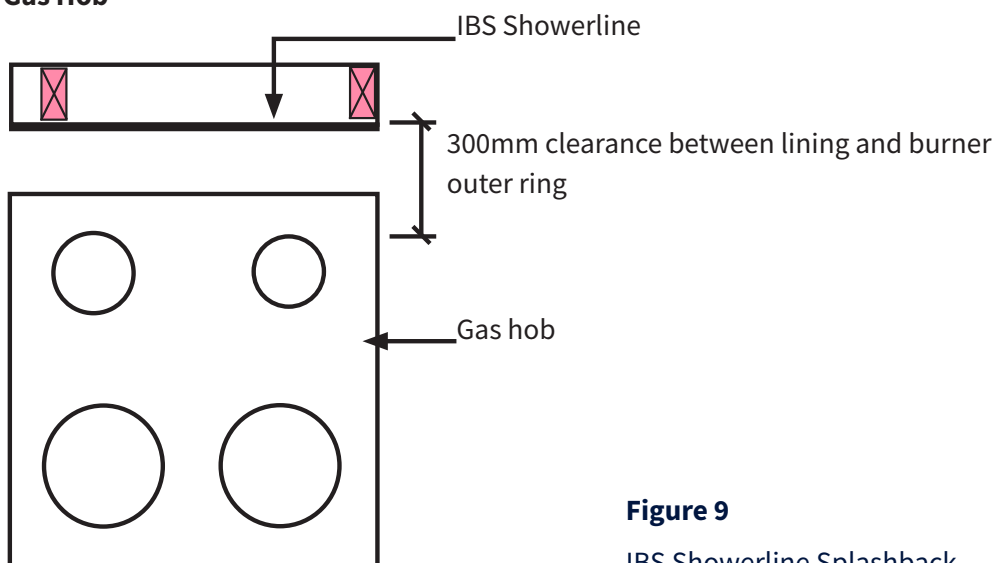

**Figure 9**

IBS Showerline Splashback

## 5.8 Creating Openings

To create openings for outlets and switches, mark the area to be removed. At the corner, drill a 15-18 mm diameter hole and cut the remainder of the hole with a fine-tooth jigsaw. Cut from the reverse side as a jigsaw can create scratches to the surface finish.

For circular holes, mark out the area to be removed and drill a series of holes as close as possible to the other using a sharp 3.5 mm – 5.0 mm speed bit.

Finish off with a utility knife and push waste material through. Alternatively, a sharp, fine-toothed hole saw of the correct diameter may be used.

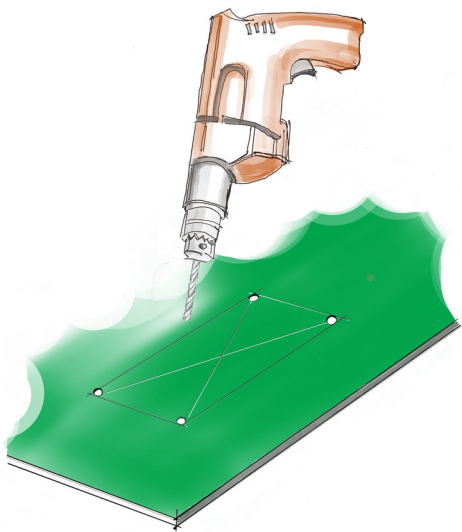

**Figure 10**  
Marking area to be removed

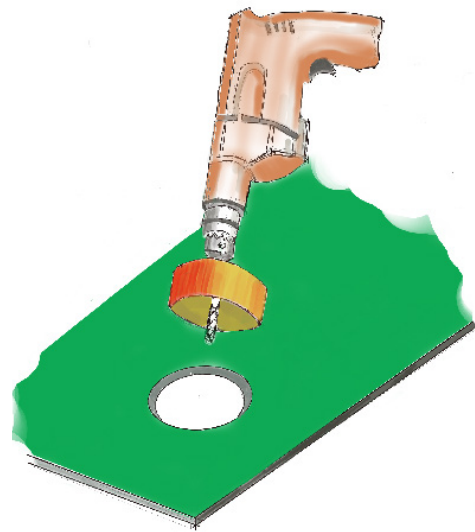

**Figure 11**  
Drilling Circular hole



## Exposed screw Fixing Only

IBS Showerline sheets can be fixed using Exposed screw fasteners at 300mm centers on all framing for walls and ceilings (see Figure 12).

This fully visible mechanical fixing method is ideal when adhesive fixing is not suitable. It is only recommended for walls in dry areas and ceilings in both wet and dry areas. Pre-drill 6mm holes for Exposed screw fasteners.

## Exposed screw detail

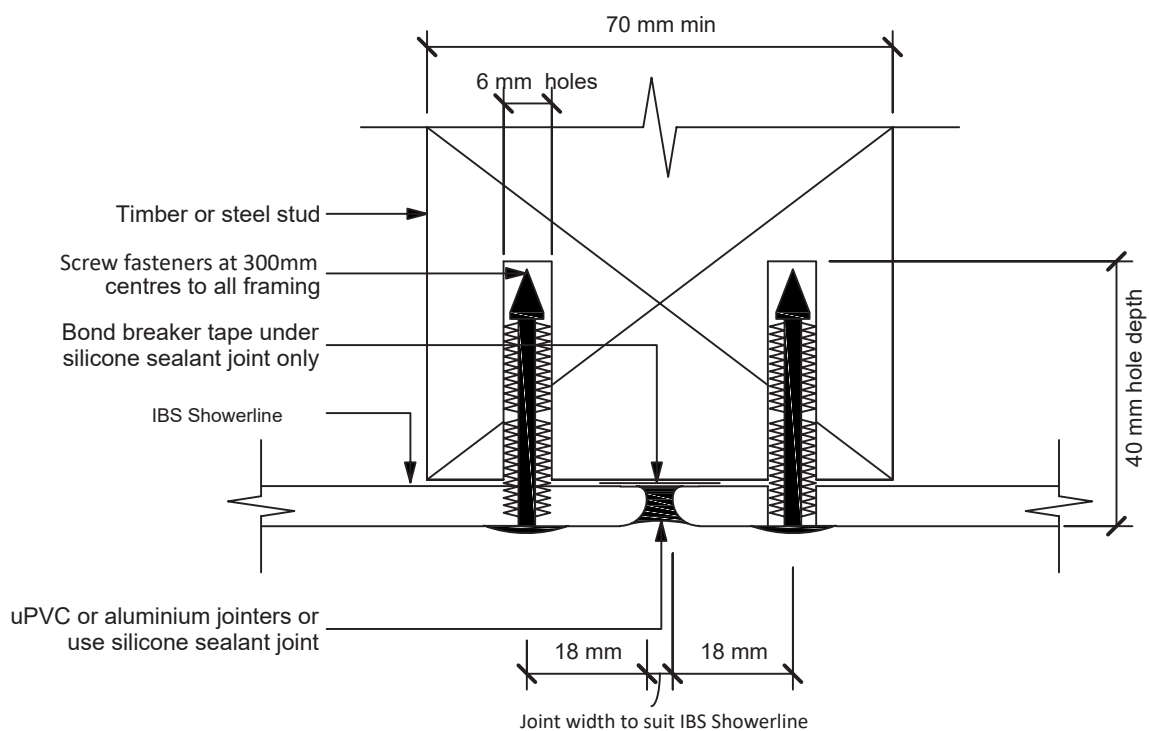

**Figure 12**

**Exposed screws fixing**

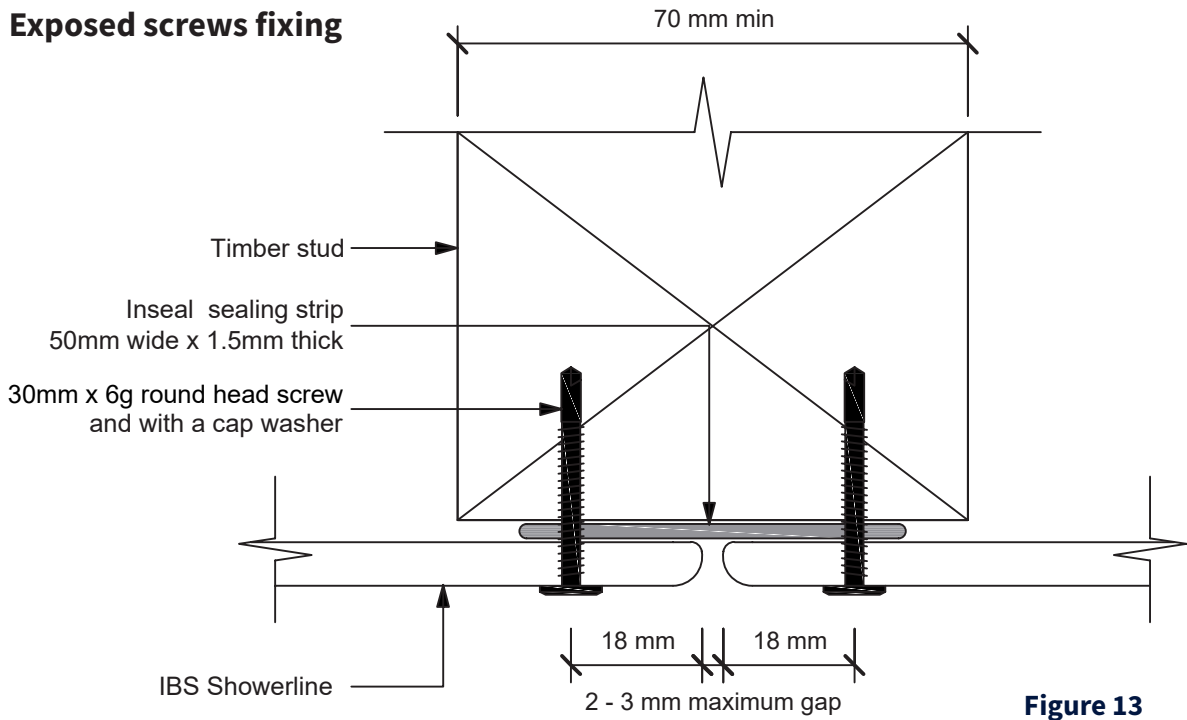

**Figure 13**

**Fixing to Ceilings - Adhesive Method**

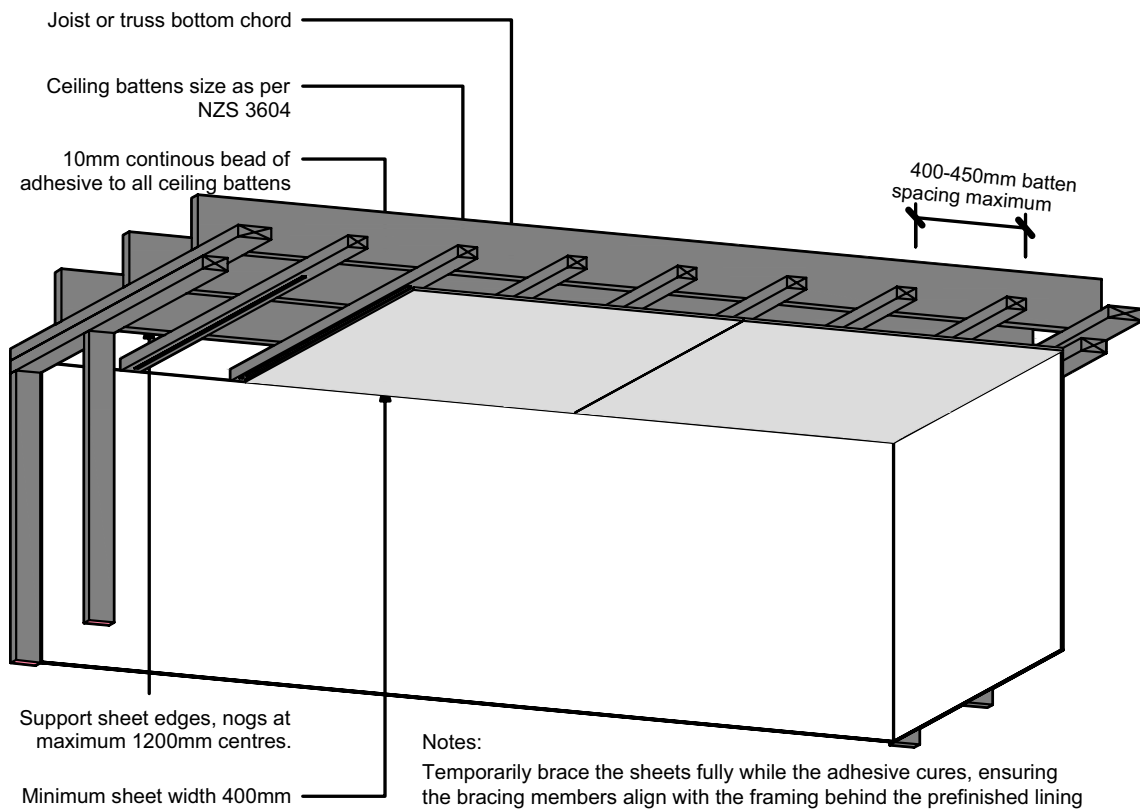

**Figure 14**

## 5.9 Trimmings and Mouldings

When installing IBS Showerline, you have options for mouldings or trims, including UPVC, aluminium, or—**for dry installations only**—a silicone joint. For any wet area installation where water may come into contact with the sheets, you must apply a silicone bead inside the moulding during installation to ensure a watertight seal

### uPVC Moulding Range

#### uPVC Jointer Dry

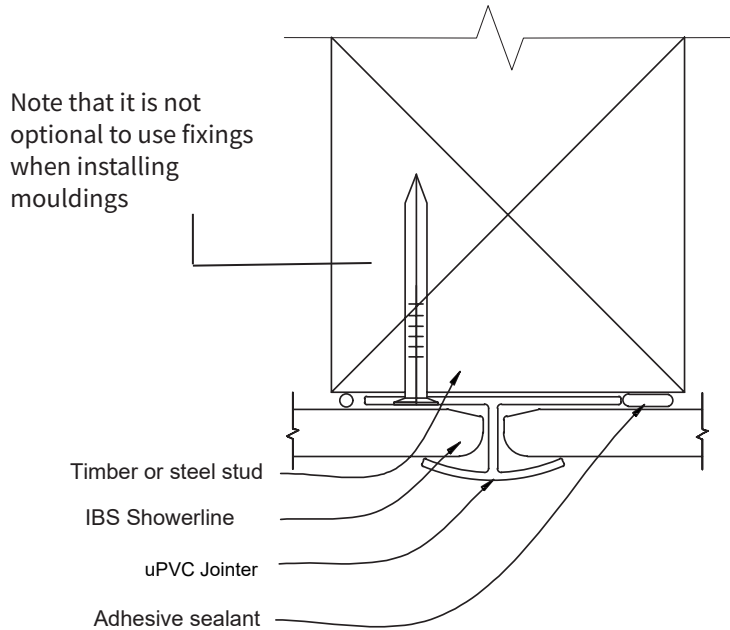

Figure 21

#### uPVC Jointer Wet

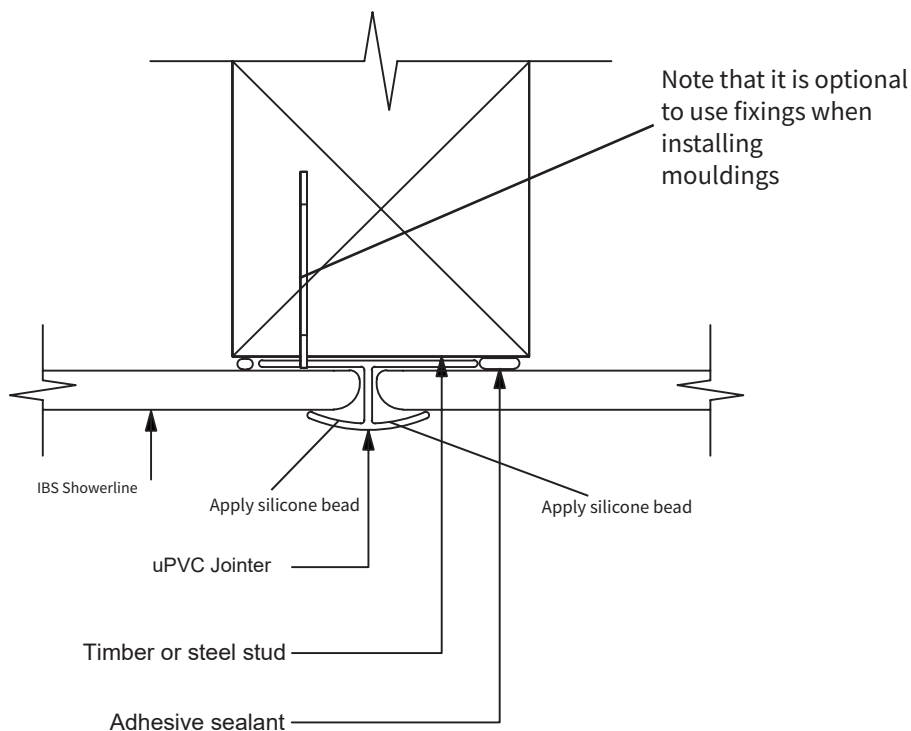
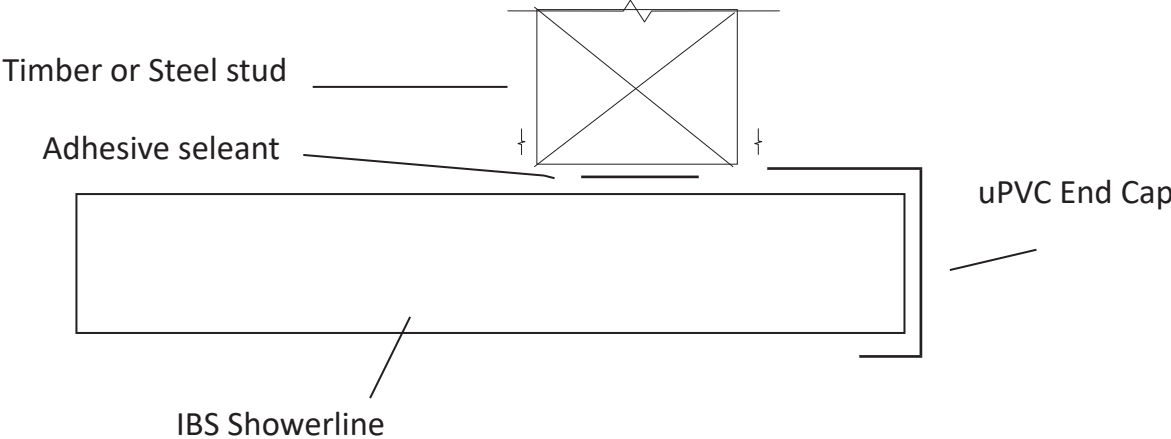

Figure 22

Note: In shower and other wet areas, the uPVC jointer must be filled with silicone sealant

**uPVC End Cap Dry**



---

**uPVC End Cap Wet**

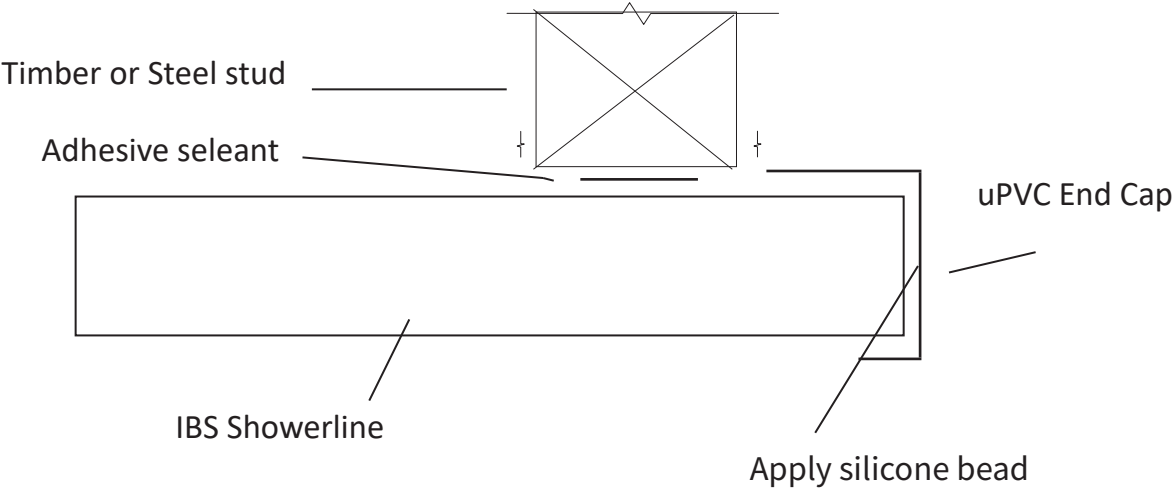

### uPVC Internal Corner Dry

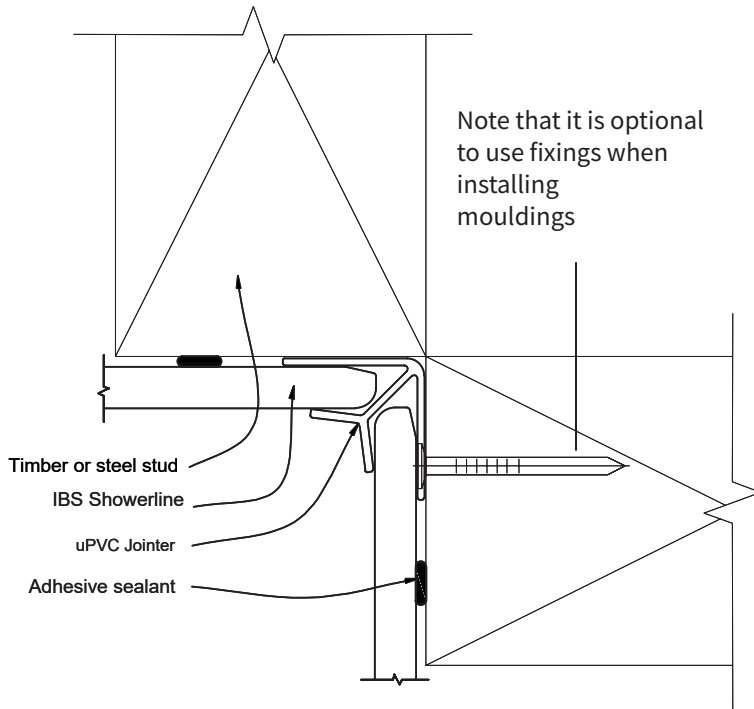

**Figure 23**

### uPVC Internal Corner Wet

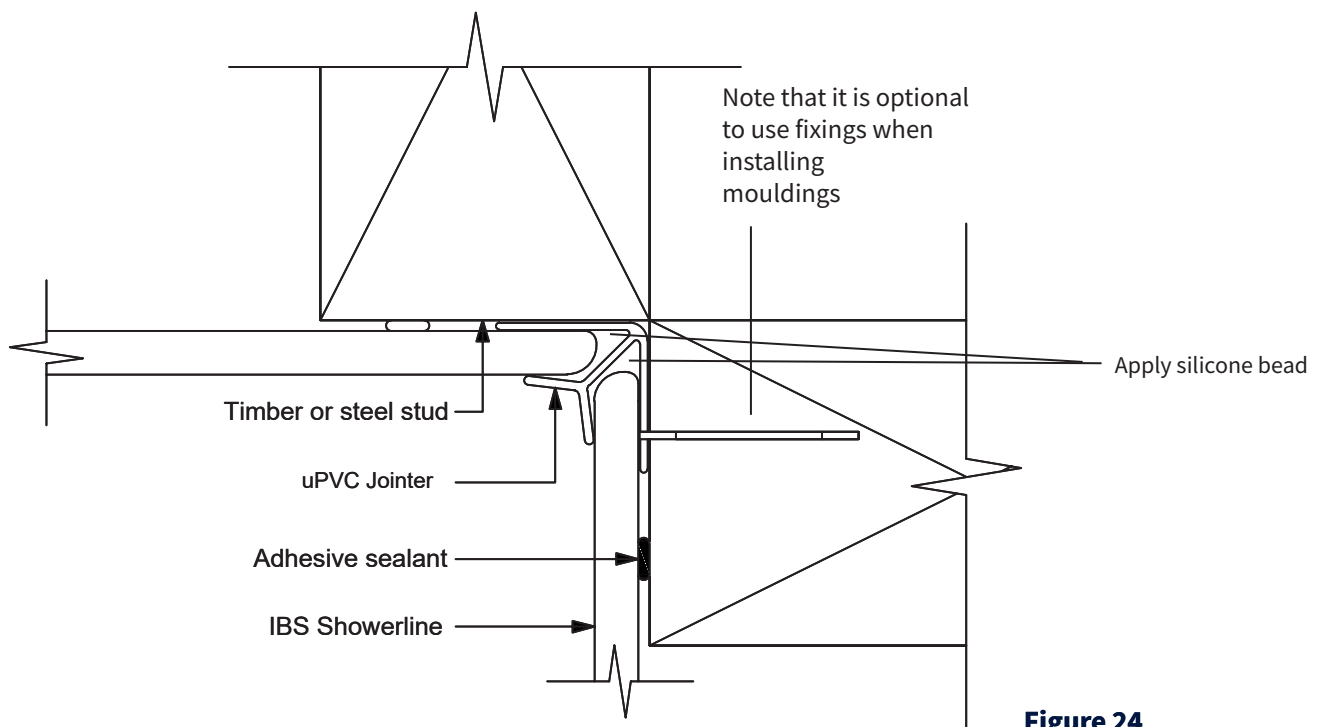

**Figure 24**

Note: In shower and other wet areas, the uPVC jointer must be filled with silicone sealant

### uPVC External Corner Dry

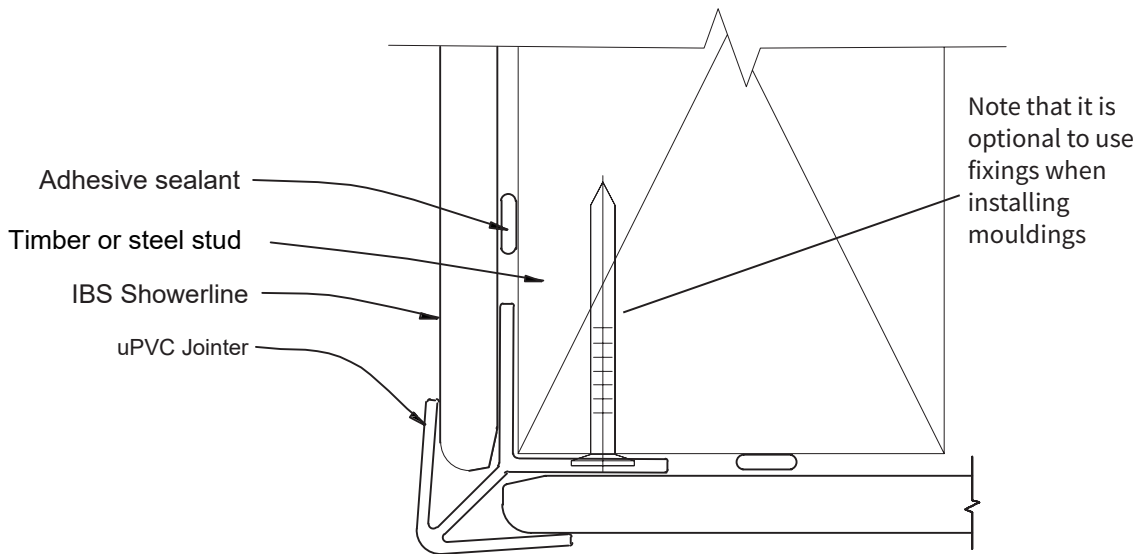

Figure 25

### uPVC External Corner Wet

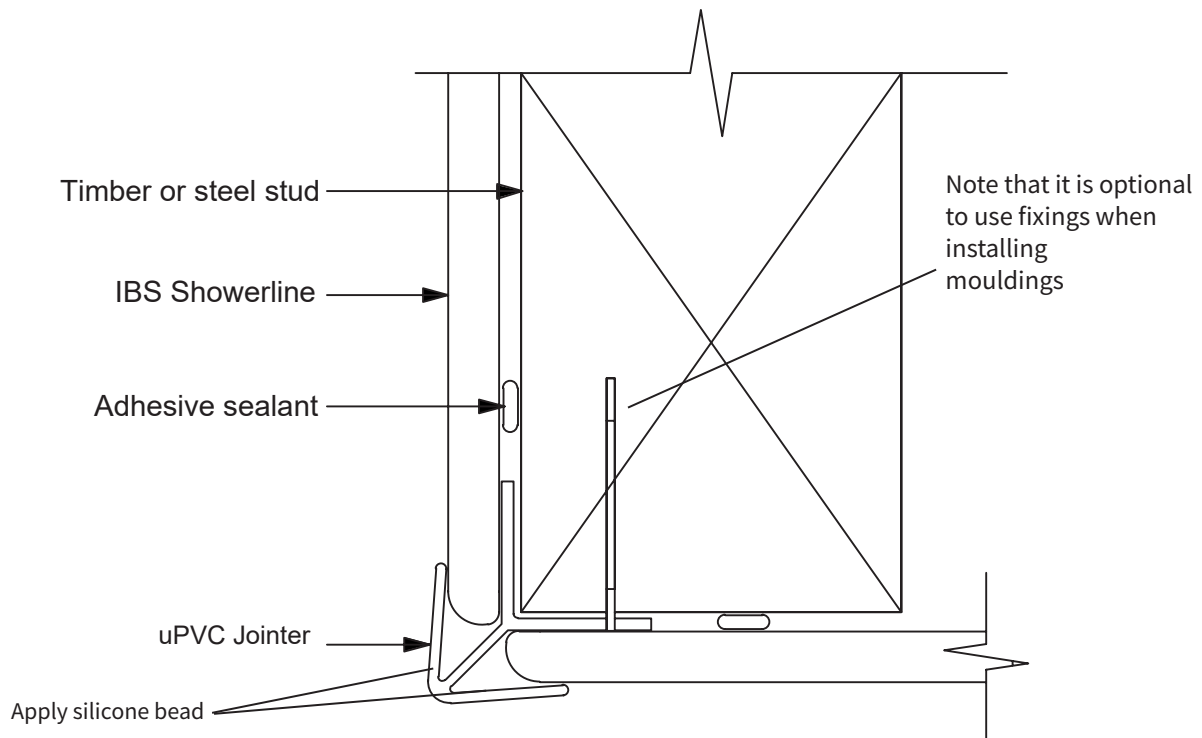

Figure 26

Note: In shower and other wet areas, the uPVC jointer must be filled with silicone sealant

## uPVC 2 Part Internal Corner Dry

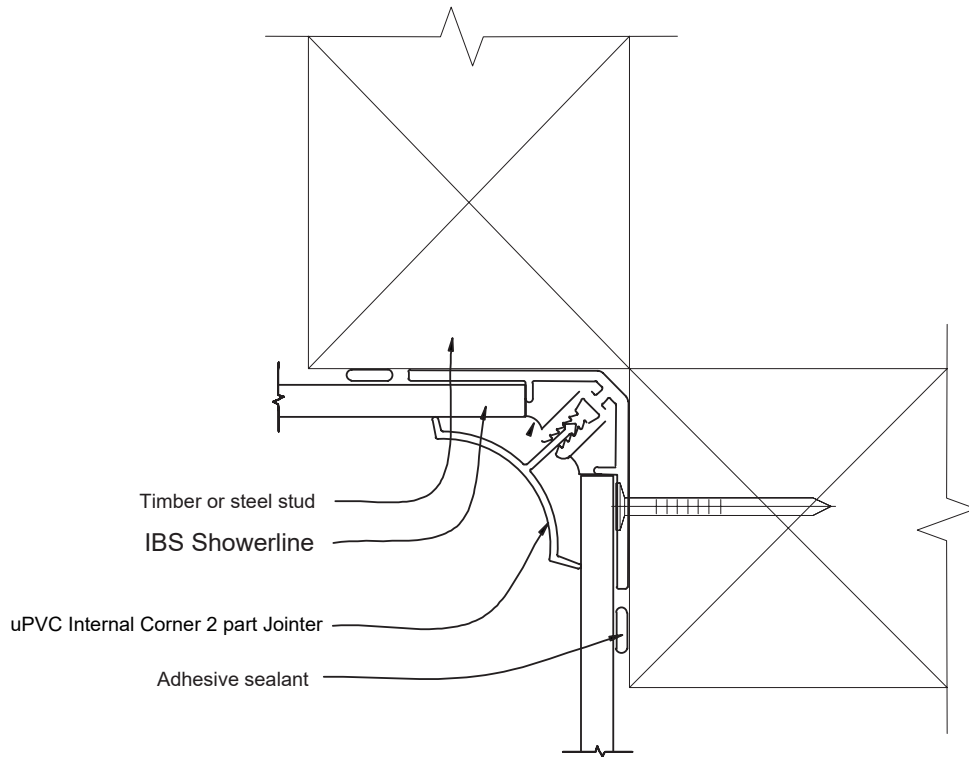

Figure 27

## uPVC 2 Part Internal Corner Wet

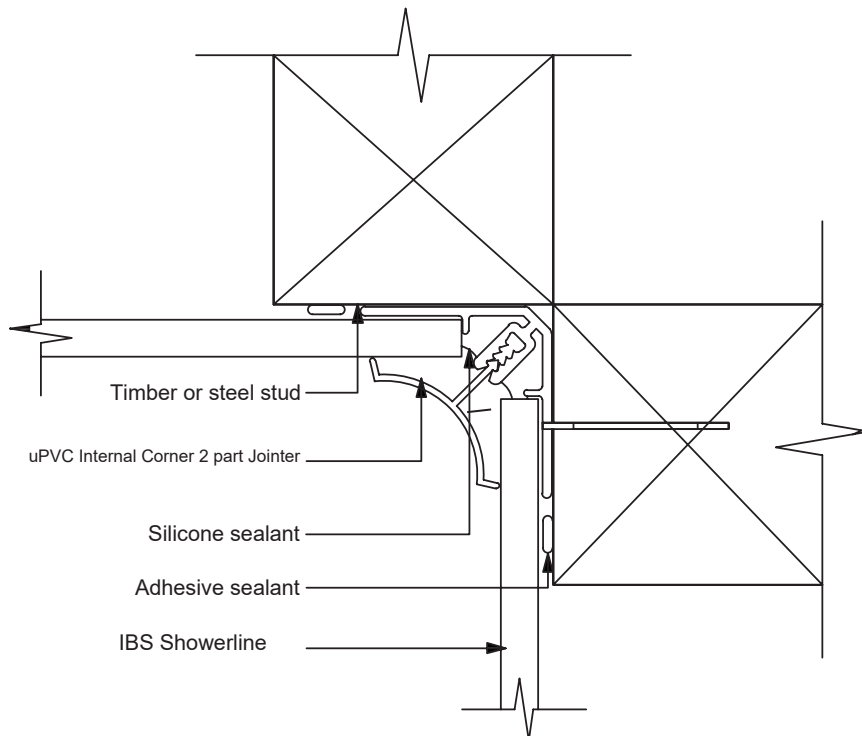

Figure 28

Note: In shower and other wet areas, the uPVC jointer must be filled with silicone sealant

## Aluminum Moulding Range

### Aluminum Dry Wall Jointer

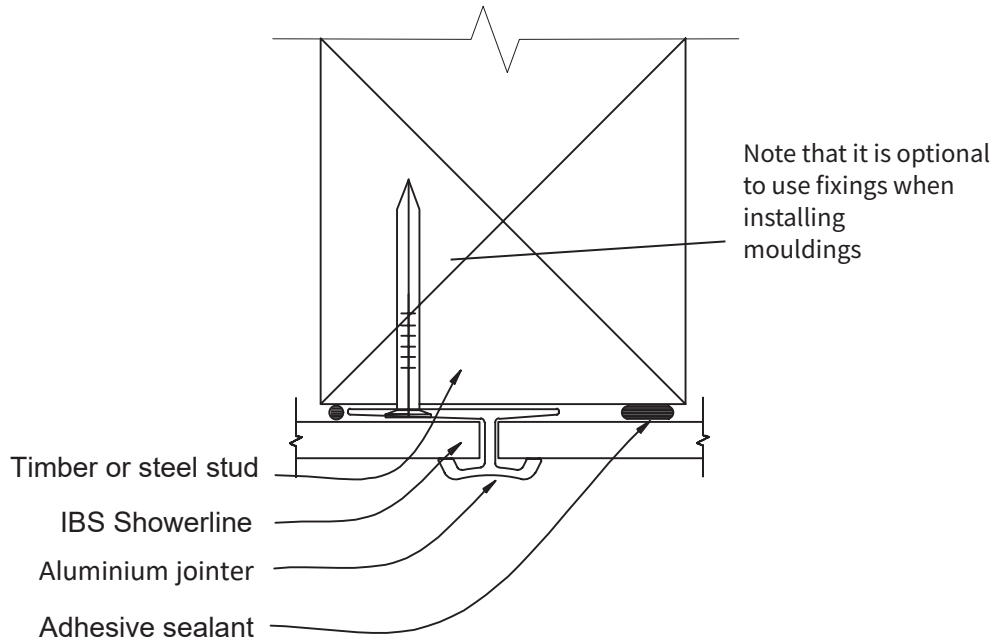

Figure 15

### Aluminum Wet Wall Jointer

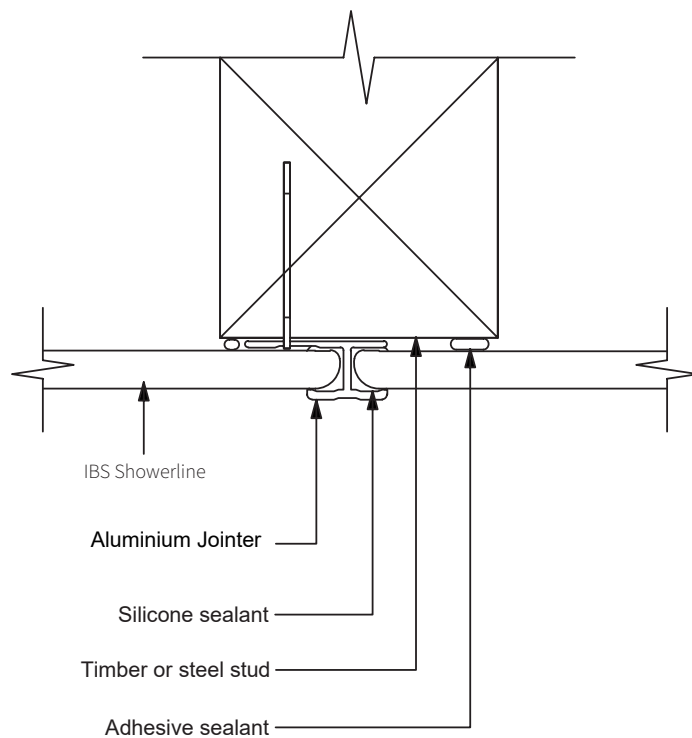
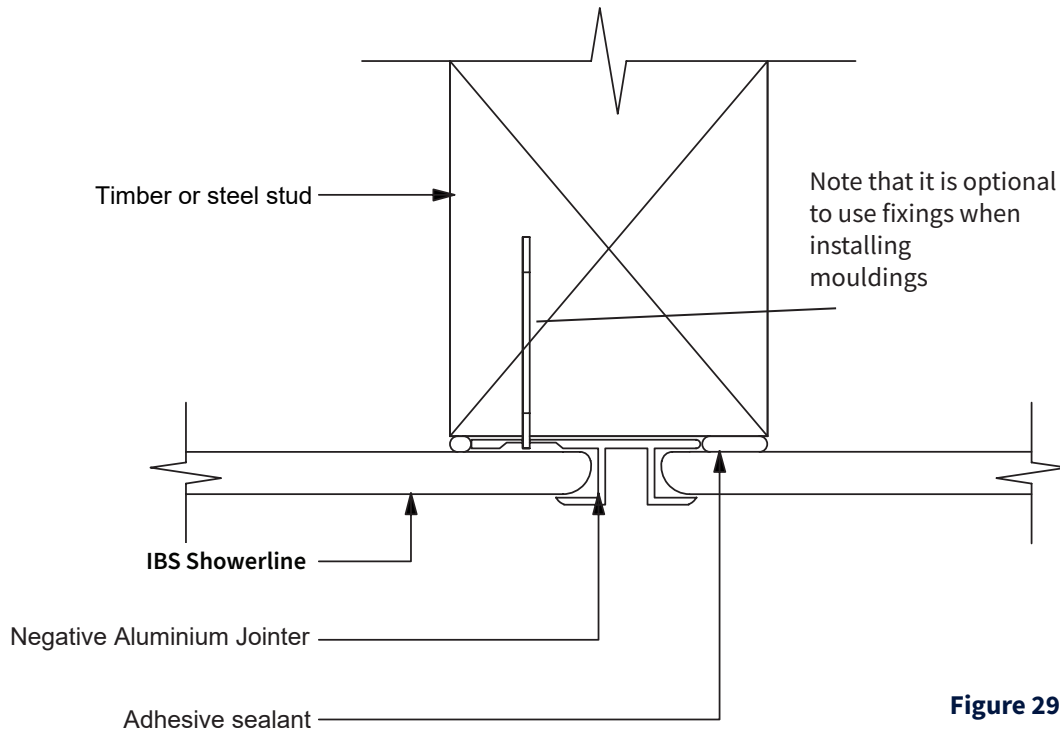

Figure 16

Note: In shower and other wet areas, the Aluminium jointer must be filled with silicone sealant

### Negative Detail Aluminium Dry



### Negative Detail Aluminium jointer Wet

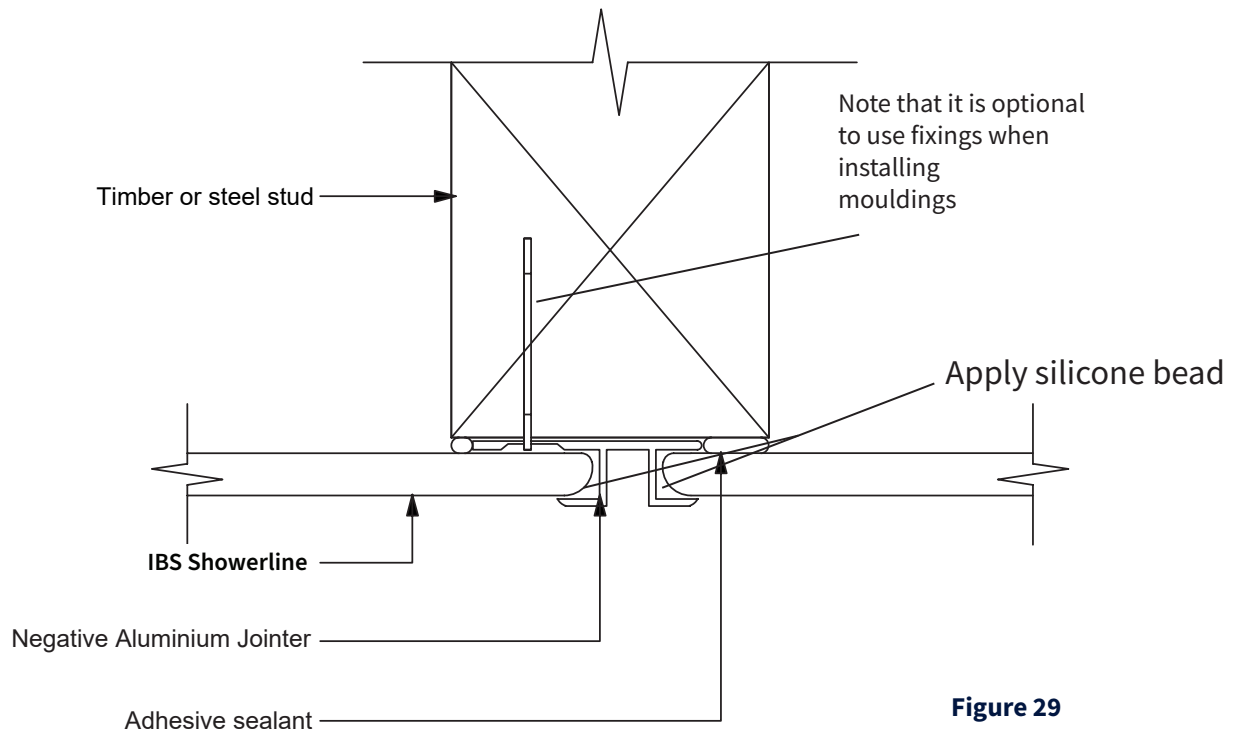

Note: In shower and other wet areas, the Aluminium jointer must be filled with silicone sealant

**Aluminum End Cap Dry**

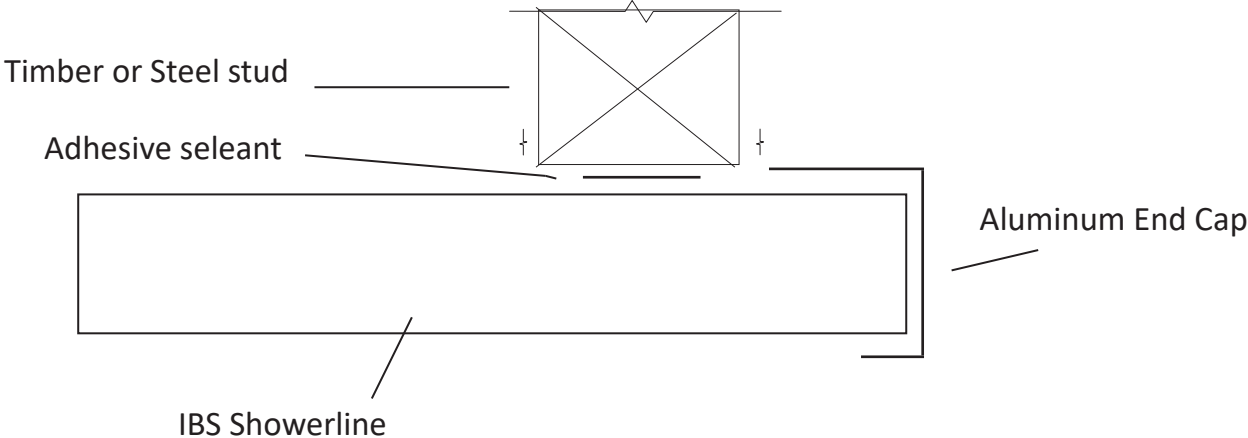

---

**Aluminum End Cap Wet**

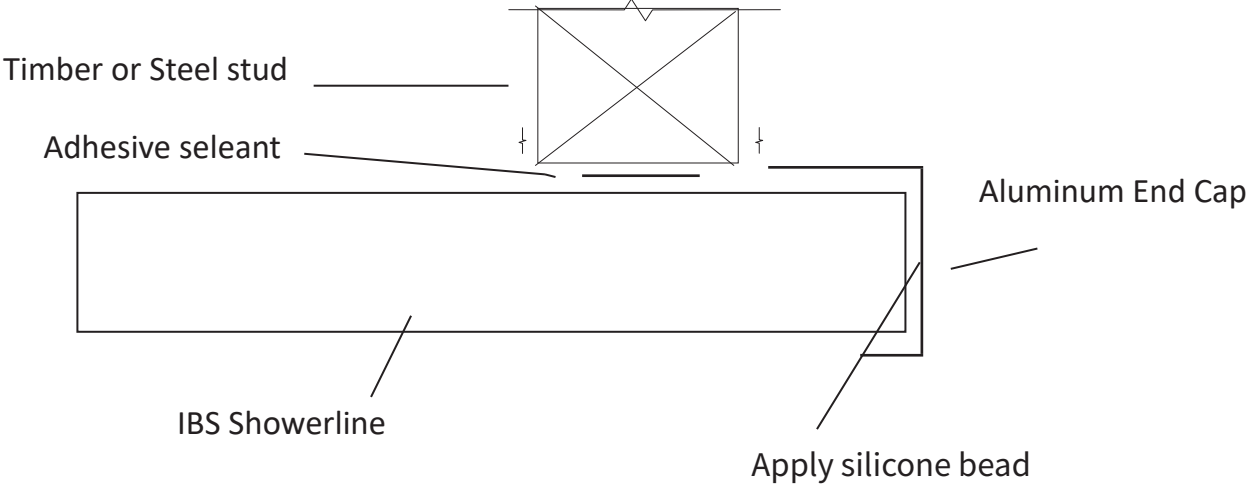

## Adhesive Sealant Aluminium Internal Corner Dry

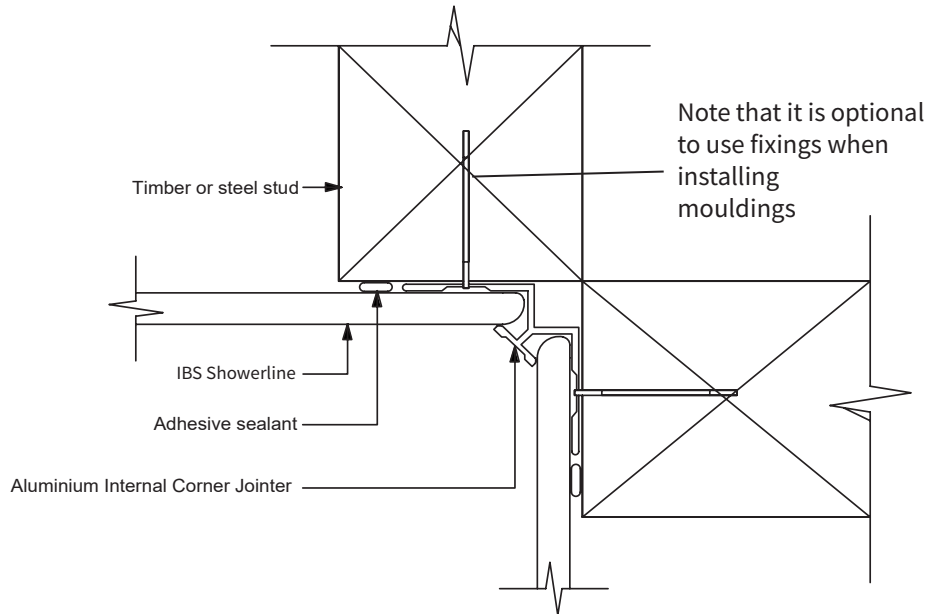

**Figure 30**

## Wet Wall Aluminium Installation Internal Corner Wet

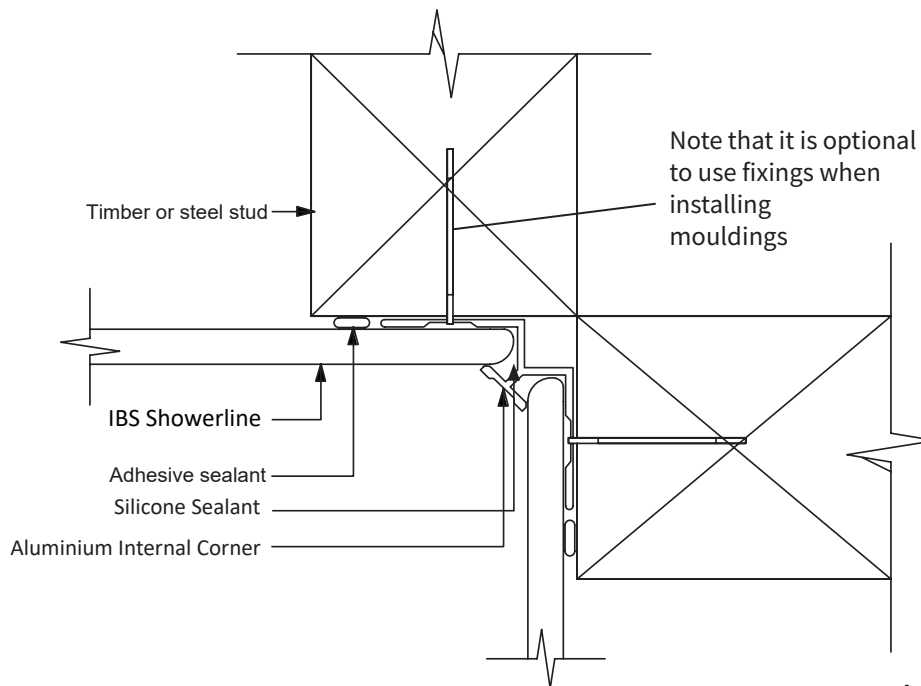

**Figure 31**

Note: In shower and other wet areas, the Aluminium jointer must be filled with silicone sealant

### Penetrations:

- Seal all fittings and penetrations through IBS Showerline with silicone or a similar sealant. Use flanges or face plates to cover the penetrations.
- Ensure proper moisture management for any details not covered in this manual. Refer to the designer for further specifications.

**Aluminum External Corner Dry**

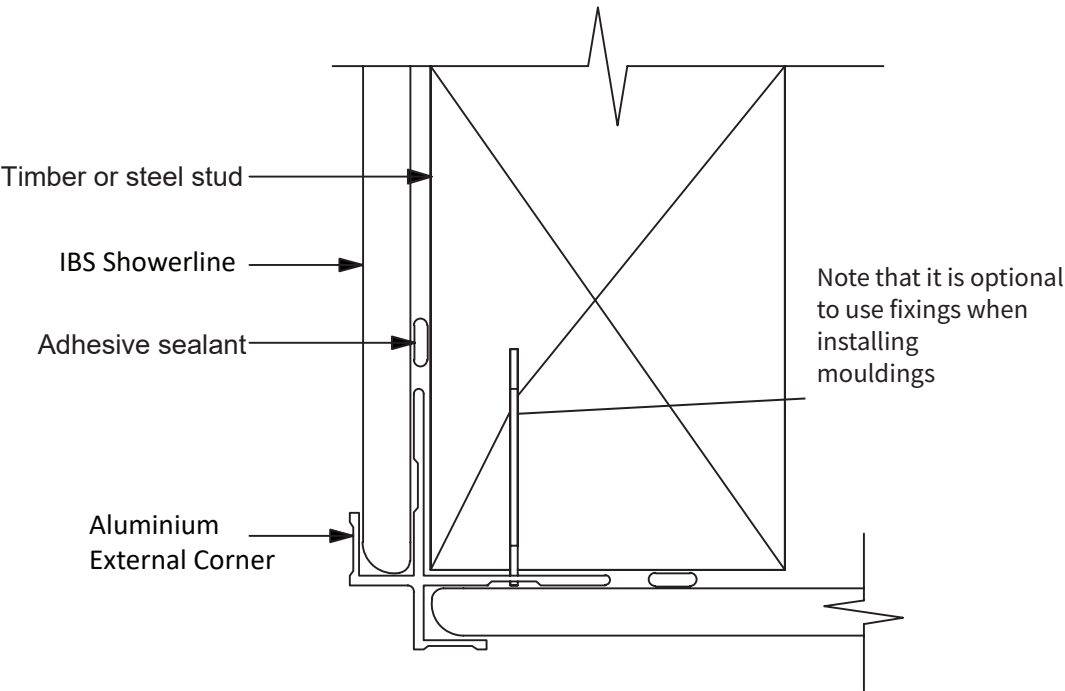

**Figure 32**

**Aluminum External Corner Wet**

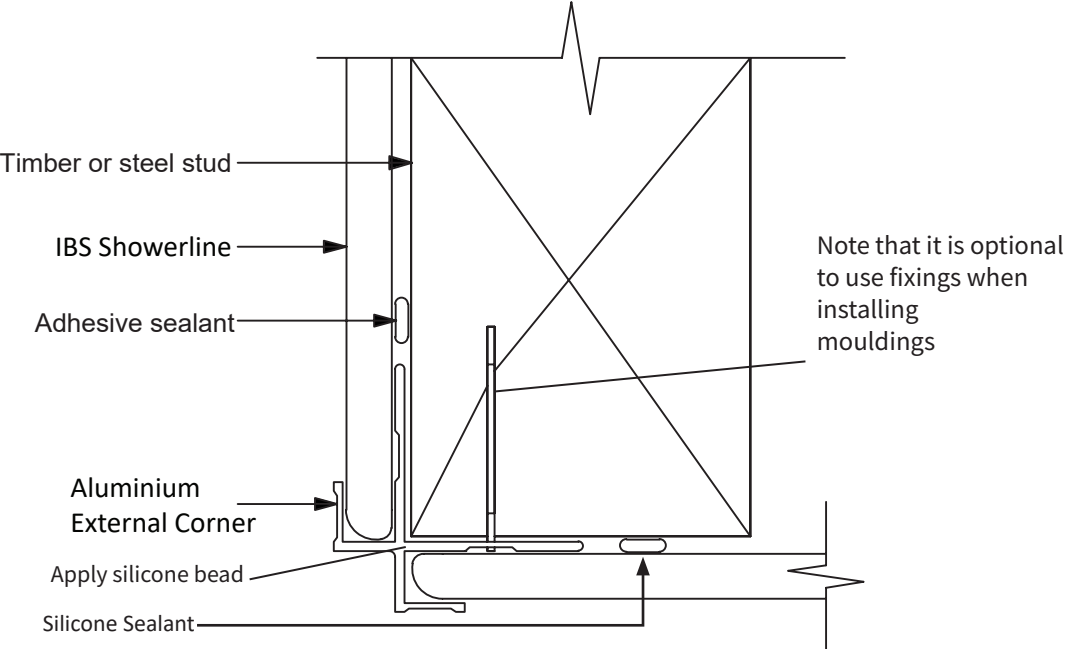

Note: In shower and other wet areas, the Aluminium jointer must be filled with silicone sealant

**Figure 33**

## 5.10 Silicone Joints

*This method is suitable for dry areas only.*

- Use in dry areas only.
- Apply bond breaker tape to framing behind joints (see Fig. 34).
- Remove protective film from sheet edge.
- Fit first sheet, then use spacers at 300mm centres. Place second sheet against spacers for correct silicone gap.
- Temporarily brace sheets until adhesive cures (per manufacturer instructions).
- Mask both sides of joint with approved tape (see Table 3).
- Prime and seal joint with silicone as directed.
- Smooth sealant, then remove masking tape while sealant is still wet.
- Avoid skin contact with sealant, use tools, gloves, or a plastic barrier.

### Flexible silicone sealant

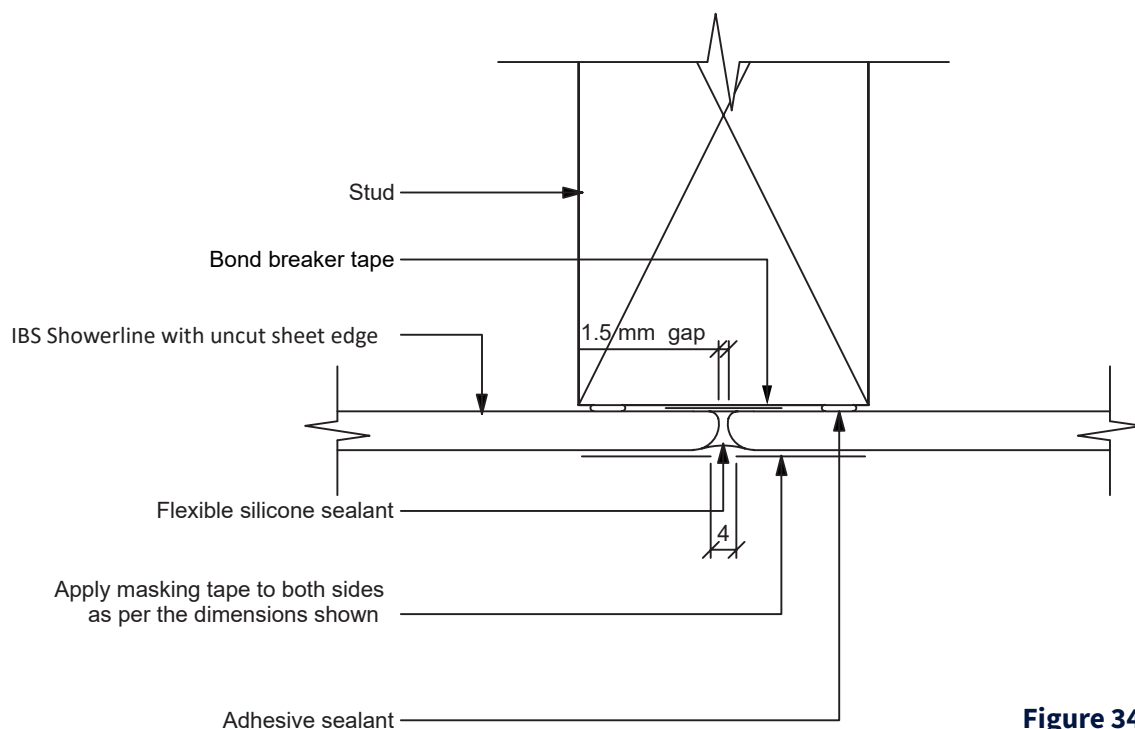

**Figure 34**

### Sealant notes:

1. Silicone seal the joint. For full application instructions refer to the sealant manufacturer.

## 5.11 Wall to Ceiling joint

### IBS Showerline scotia mould options

Use a timber moulding, cap moulding, or a uPVC scotia mould.

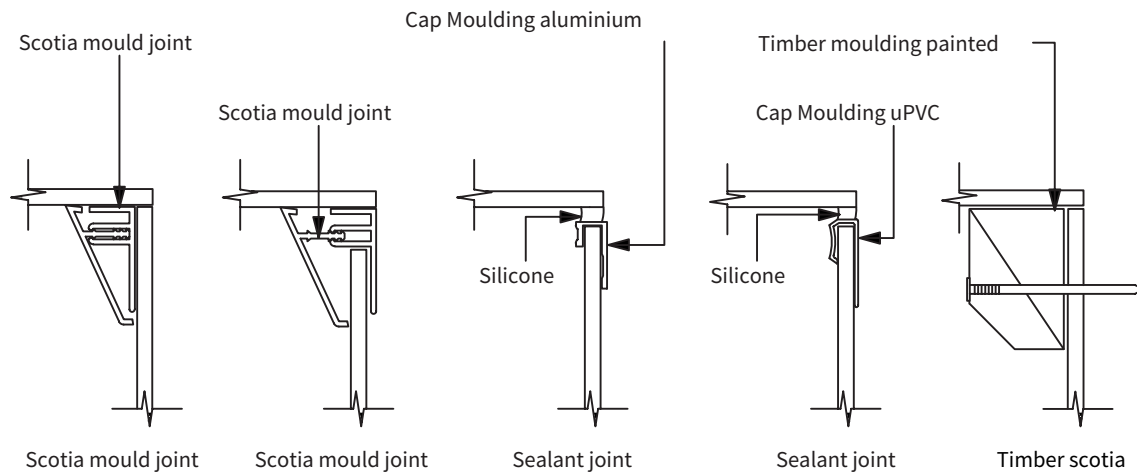

**Figure 35**

## 5.12 Wet Area Wall Joints

When using the uPVC or aluminium jointer method for wet area applications, ensure that all sheet edges are sealed into the jointers with silicone sealant. A sealant-only joint should not be used in shower applications.

### Joints, Corners & Capping

You may secure mouldings with nails at a maximum of 300mm centres.

When using a cap mould, shorten the vertical jointer to suit the sheet thickness.

## Lining wall to tiled floor

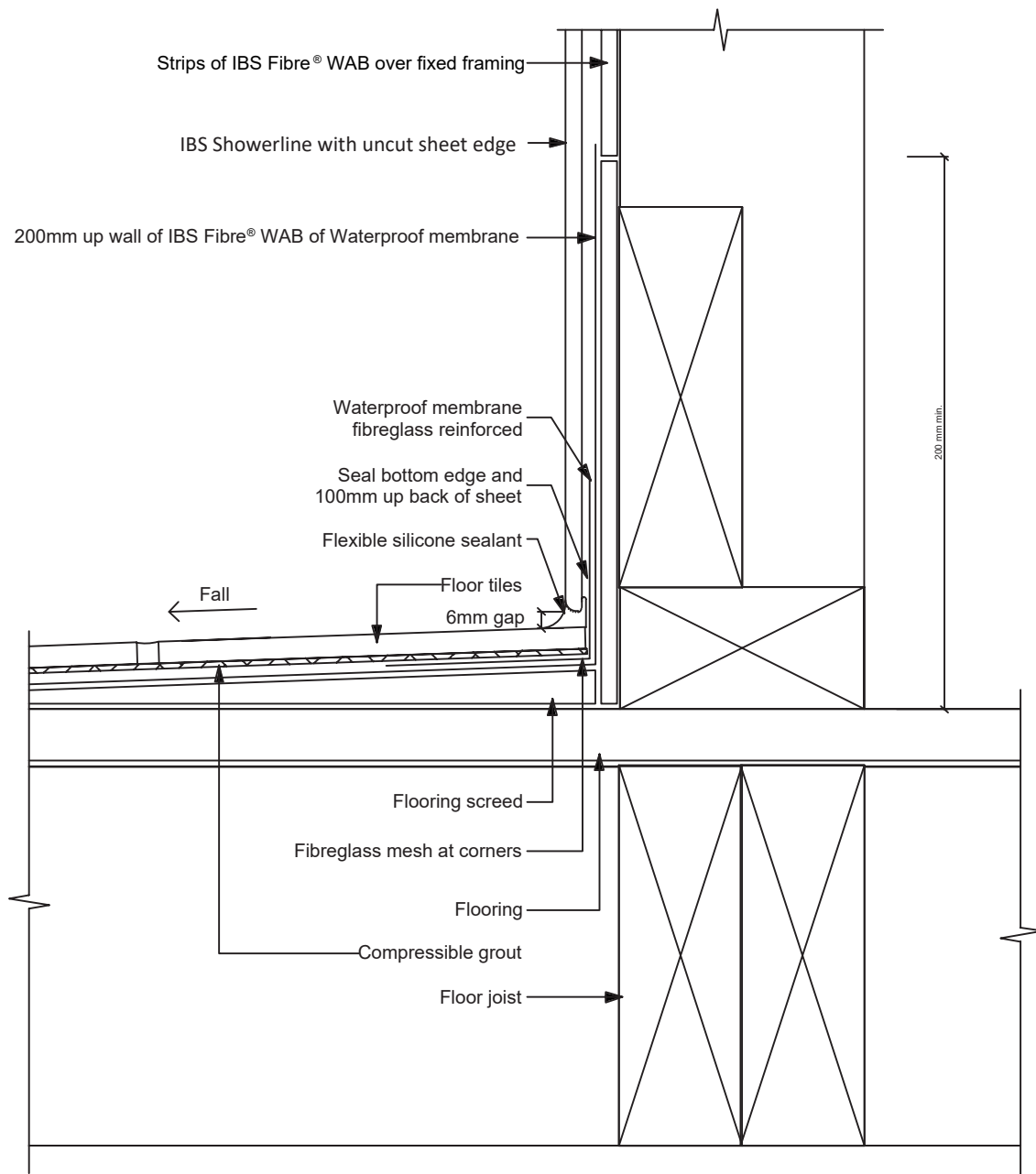

**Figure 36**

Note 1: The floor should be laid with two directional slopes towards the corner waste.

Ensure the perimeter edge of the waste hole is at least 50mm from the edge of the sheet or wall. Build up the slopes around the waste hole before applying the waterproof membrane.

Note 2: The floor tiles must be installed prior to the installation of IBS Showerline.

### IBS Showerline lining wall to tiled floor and upstand detail

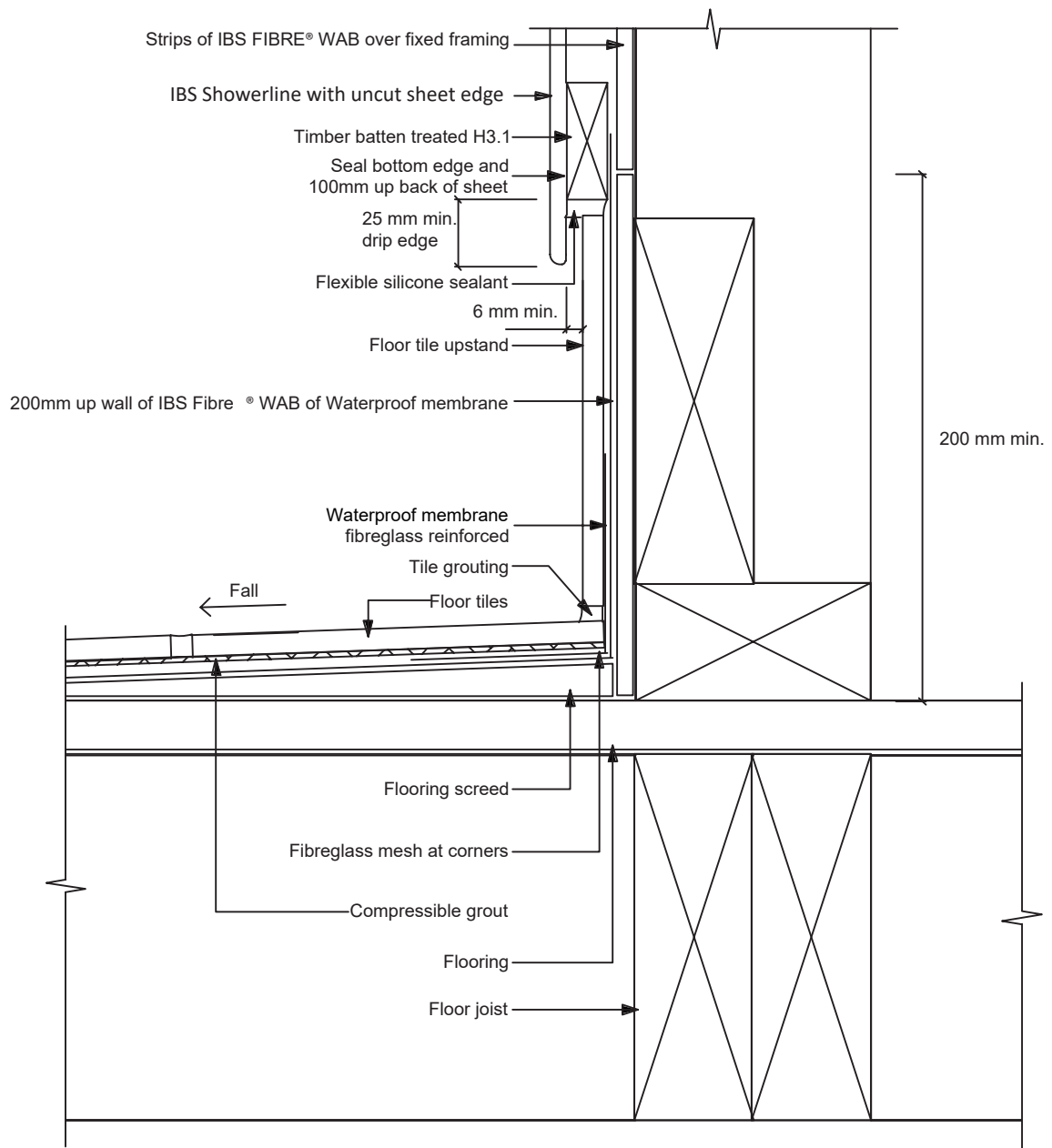

**Figure 37**

Note 1: The perimeter edge of the waste hole should be at least 50mm from the edge of the sheet or wall.

Build up the slopes around the waste hole before applying the waterproof membrane.

Note 2: The floor tiles must be installed prior to the installation of IBS Showerline.

## 5.13 Around Baths and Showers

### Lining bath sealant detail

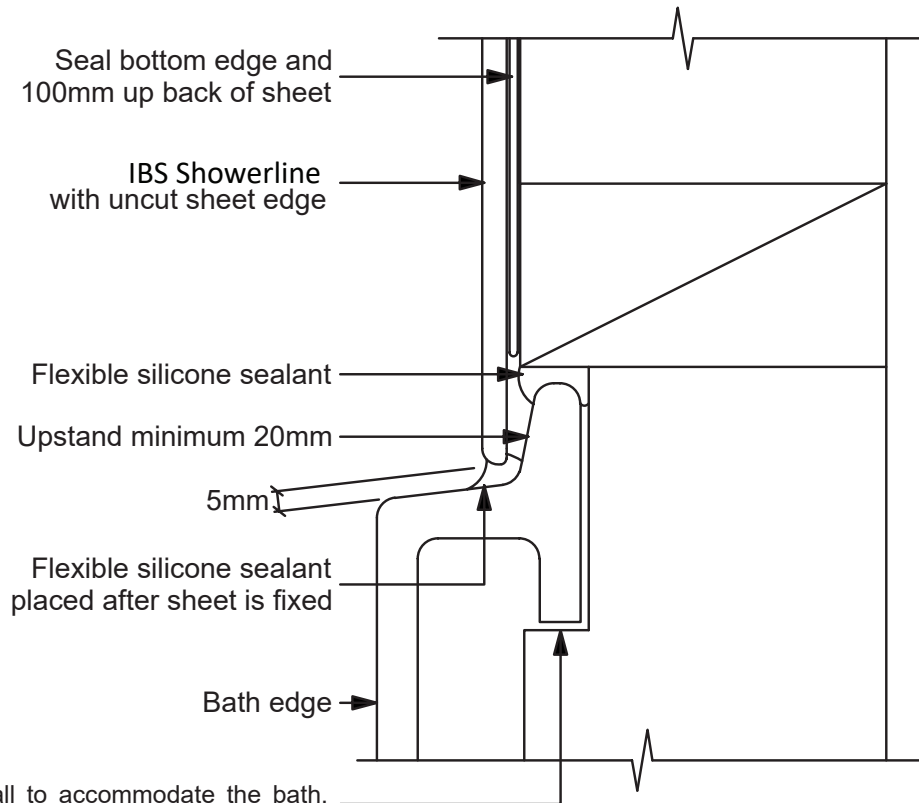

Notch the stud wall to accommodate the bath, or alternatively, install battens over the stud wall.

**Figure 38**

#### **Penetrations:**

Seal all fittings and penetrations through IBS Showerline using silicone or an equivalent sealant.

Use flanges or face plates to cover the penetrations.

For details not covered in this manual, ensure appropriate moisture management, consult the project designer.

#### **Around Baths and Showers:**

Use either a silicone seal or a uPVC bath mould around baths.

**Lining uPVC bath mould**

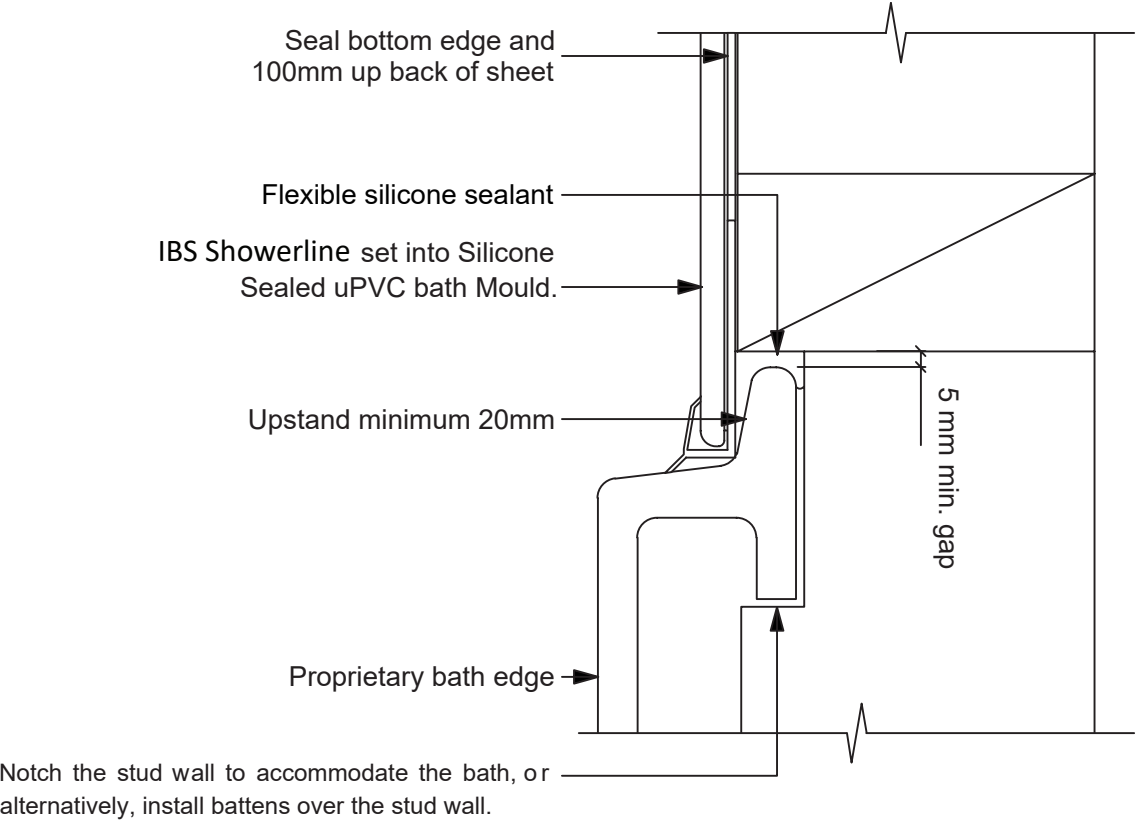

**Figure 39**

## Lining sealant bath acrylic shower detail

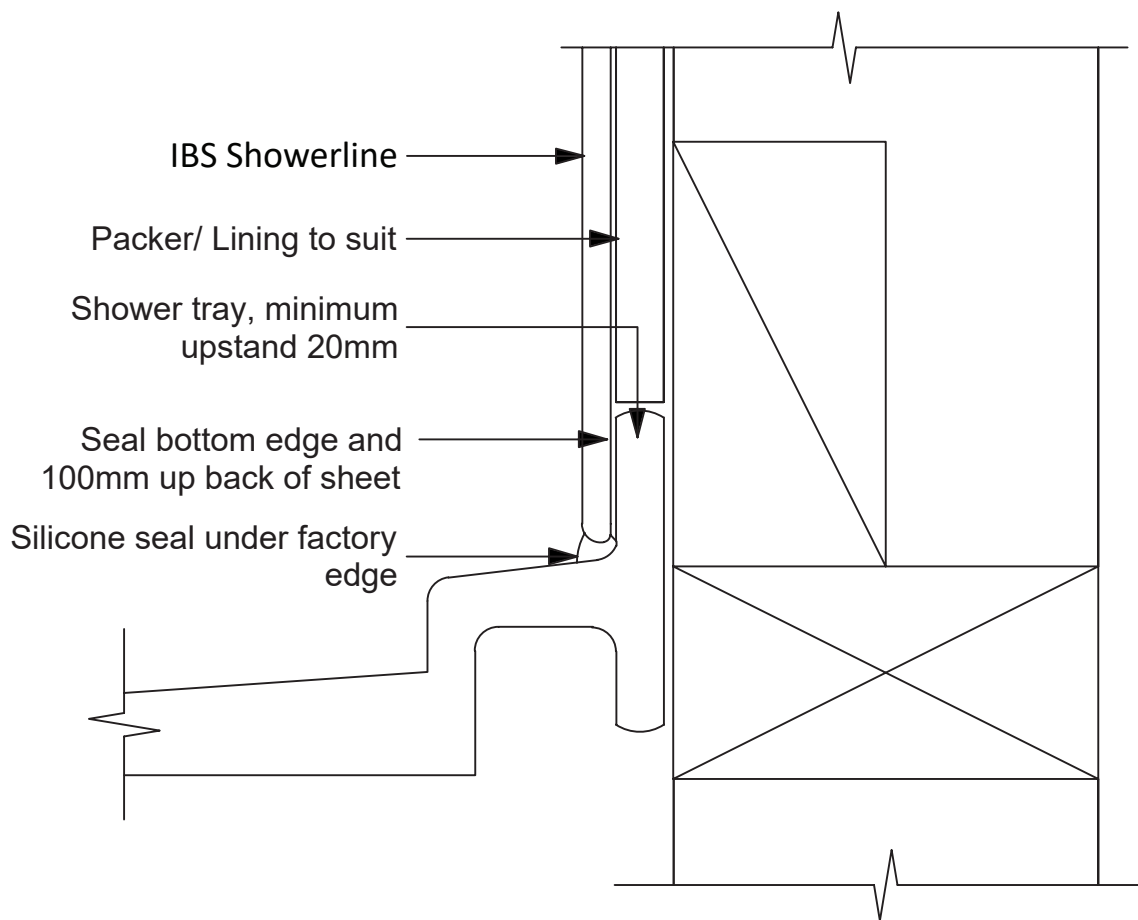

**Figure 40**

## Indoor Swimming Pool Applications

Chlorine environments are not suitable for some wallboard adhesives. Therefore, when using IBS Showerline Lining in areas like indoor swimming pools, consult the adhesive manufacturer to confirm its suitability for this application, or consider using stainless steel screws with cup washers.

For timber framing in these environments, it is recommended to use a higher level of timber treatment. IBS Showerline lining requires more frequent cleaning when used in a chlorine environment.

### 5.14 Stainless Steel Shower Tray

For a stainless-steel shower installation it is essential that a drip edge is formed at the bottom of the sheet (refer Figure 41).

**Note:** Paints are not suitable for wet area applications (splash zones) and should not be relied upon for waterproofing.

#### Stainless steel shower base

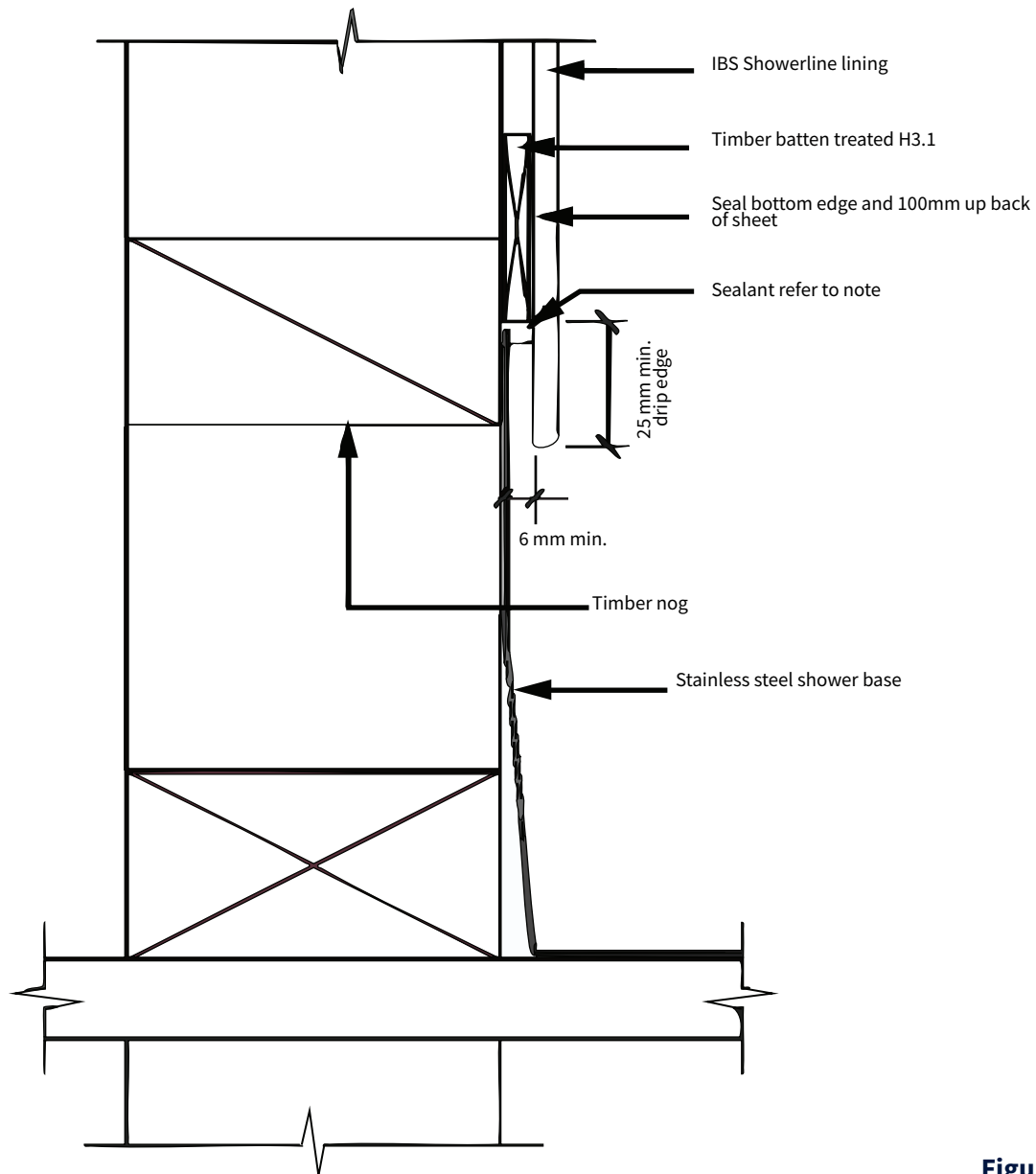

**Figure 41**

Note: It is important to use sealant here to prevent possible damage to the framing.

# 6. Finishing

---

## 6.1 Removing Protective Layer

The protective coating should be removed from the panel as soon as the adhesive has cured no more than 24 hours after installation. However, in certain areas, such as the edges, the protective layer will need to be carefully removed.

This is necessary to allow for the trimming of the boards, the creation of any required openings, or the installation of trims. It's important to ensure that only the necessary sections of the protective coating are removed to maintain the integrity of the rest of the surface.

## 6.2 Cleaning IBS Showerline Panels

Following the removal of the protective layer, it is essential to clean the Showerline panels to maintain their pristine appearance. Use a solution of warm soapy water and a soft cloth to wipe down the surface.

This gentle cleaning method will effectively remove any dust, adhesive residue, or fingerprints without causing any damage.

Avoid using abrasive cleaning products, steel wool, or cream-type cleaners, as these can scratch or dull the surface.

Regular cleaning with warm soapy water will help keep the Showerline panels looking new and ensure their longevity

# 7. Care, Maintenance

---

## 7.1 Care, Maintenance

When cleaning, verify that the sealant and fixings are properly in place, ensuring that the IBS Showerline sheets have not shifted or moved during the cleaning process. Additionally, check for any signs of wear or damage to the sealant or fixings to maintain optimal performance.

IBS Showerline sheets should be regularly cleaned. If the sheets are soiled with water-soluble dirt and stains, a simple solution of 5% detergent and warm water should be sufficient to remove the stain.

- Regular washing or wiping clean protective surfaces.
- Ensuring the paint system is maintained.
- Avoid the use of steel wool or abrasive cleaning products.
- For difficult or non-water-soluble stains, a household cleaning solution may be used.
- Do not use abrasive, aggressive substances, chloride-based cleaning products, or solvents, including cream type cleaners.
- Commercial cleaners, that are mixed on-site, must not be used.
- Use of any of these unapproved cleaners will void the warranty.



# 8. Warranty

---

Independent Building Supplies Limited (IBS) supplies sustainable building products, which when used and installed in accordance with all relevant instructions and specifications, will be fit for purpose.

As part of our commitment to performance, IBS provides a warranty in respect of IBS Showerline (Product) in accordance with the following terms and conditions.

These terms and conditions must be read in conjunction with all product specific relevant and applicable technical documentation, information and guidelines published or referenced by IBS from time to time (Specifications) in relation to the Product.

## 1. IBS warrants that:

- i. At the time of delivery to the merchant or site (where applicable) the IBS supplied Product will:
  - a. Be free from freight related defects;
  - b. Be free from defects that may have arisen through defective factory workmanship or materials; and
  - c. Conform to the performance characteristics listed on the applicable pass™ (warranted condition).
- ii. Once installed properly and in accordance with all appropriate Specifications the Product will continue to meet the relevant provisions of the building code as described on the applicable pass™ (warranted performance).

## 2. Date warranty valid:

- i. IBS warrants:
  - a. The warranted performance for 10 years from proven date of purchase or dispatch from IBS whichever date is the earlier; and
  - b. The warranted performance for the durability period as specified by the NZ Building Code.

The durability period begins from the date the product is first installed or two months after the date of delivery, whichever is the earlier.

- ii. All enquiries relating to this warranty must (in the first instance) be directed to the place of purchase, the supplier or the installer.

- iii. By submitting a claim under the warranty, you grant IBS and its agents, consultants and contractors full rights of access, at no cost and at any reasonable time, to the relevant building to inspect the Product and the installation method for the purpose of determining the validity of the claim.

**1. In the event a breach of the warranty is proven, the following applies:**

- i. For any valid and accepted breach of a warranty, IBS will, in its sole discretion, either:
  - a. Repair, replace or rectify the defective Product; or
  - b. Refund the purchase price of the defective Product. Where applicable the value will be reduced pro-rata, based on the remaining life of the Product (as set by the relevant durability requirements of the NZ Building Code).
- ii. Any action taken by IBS in satisfaction of a warranty claim shall constitute full and final settlement of all claims and IBS's total liability related to a breach of the warranty is limited to the direct cost to IBS of performing either of the above options.
- iii. IBS reserves the right to supply other comparable materials or products should the warranted Product no longer be supplied by IBS.

**2. This warranty is subject to the following:**

- i. Receipt of evidence of the date of purchase of the Product.
- ii. Evidence satisfactory to IBS of failure of the Product.
- iii. Receipt of a written claim from the claimant either within 30 days of when the defect or failure of the Product would have become reasonably apparent or, if the defect was reasonably apparent prior to installation, then the claim must be made prior to installation.
- iv. The claim must include full details of the alleged defect in the Product.
- v. Evidence satisfactory to IBS that all design, storage, transport, installation and maintenance requirements for the Product have been met or carried out in accordance with the Specifications and in terms of best building practice and the building code.
- vi. The warranty does not cover failure or problems caused by defective use, failure relating to improper design of the project structure, structural failure, settlement, movement of materials to which the Product is attached or dependent on, acts of God including but not limited to earthquakes, cyclones, floods or other severe weather conditions, inadequate maintenance, growth of mould, mildew, fungi, bacteria or any organism on any Product, or acts or omissions of a third party over whom IBS has no control.

- vii. The warranty does not cover failure or loss arising from the failure to follow all relevant IBS advice and requirements or failure to adhere to the Specifications.
- viii. Normal wear and tear, including non- performance related changes, are excluded from this warranty.
- ix. All relevant information relating to the Specifications is uncontrolled in printed format and is available from IBS (refer to [www.ibs.co.nz](http://www.ibs.co.nz)).

### **3. Limitations**

- i. IBS will not be liable for a warranty claim unless:
  - the use of the Product meets the installation, storage, transport, use and maintenance requirements and Specifications in respect of the Product and the customer is responsible to ensure these are received and understood;
  - and (b) the claim procedure set out in these terms is correctly followed and the required information is provided.
- ii. IBS will in no circumstances be liable for:
  - a. Any damage or loss caused by a person other than IBS, or by any other factor outside IBS's reasonable control, including without limitation fire, moisture, lightning, liquid, strike or lockout, chemicals, insects or animal;
  - b. Any damage or loss caused or contributed to by incorrect or improper use or a failure to comply with all Specifications and all applicable building codes, regulations and legislation;
  - c. Neglect, abuse, misuse, growth of mould/ mildew/fungi/bacteria or other organism; or
  - d. Any direct or indirect loss, or consequential loss or damage, of any kind.
- iii. All warranties, conditions, liabilities and obligations implied by law or custom (other than the warranties in these terms) are excluded to the fullest extent permitted by law, and without limitation, where the Product is provided for the purposes of trade, the provisions of the Consumer Guarantees Act 1993 shall not apply.
- iv. Except as provided in these terms, IBS will not be liable (under legislation, contract, tort, or otherwise including in equity) in respect of any defects in the Product or for any other cost, expense or liability caused by or related to the use of the Product.

## 9. Technical Properties

IBS Showerline is an excellent choice for wet and high-moisture environments due to its impressive durability and ease of installation. With its impact-resistant properties, it can withstand everyday wear and tear, making it ideal for high-traffic areas like bathrooms and kitchens.

The panel features a beautiful, consistent colour with a curtain-coated finish that enhances its aesthetic appeal. Its aluminium face and back ensure that it will never rot, offering long-lasting performance.

Additionally, the surface is protected by a plastic film to safeguard against damage during installation. Easy to cut and install, IBS Showerline is both a practical and stylish solution for your building needs.

### IBS Showerline Component Properties

TABLE 3 - IBS Showerline Performance Claims		
NZ Building Code clauses	Compliance statement	BASIS OF COMPLIANCE Demonstrated by
B1 Structure B1.3.1, B1.3.2 B1.3.3 (A, J, Q) B1.3.4 (B, C, D, E)	Alternative Solution	<ul style="list-style-type: none"> <li>› Supplier technical datasheet.</li> <li>› Comparisons with other ACM performance characteristics.</li> </ul>
B2 Durability B2.3.1 (C) B2.3.2 (B)	Alternative Solution	<ul style="list-style-type: none"> <li>› PE is resistant to most chemicals.</li> </ul>
C3 Fire Affecting Areas Beyond The Source C3.4 (A)	Alternative Solution	<ul style="list-style-type: none"> <li>› Tested to EN13501. Achieves B,S1, d0. SGS [22/10/2010].</li> </ul>
E3 Internal Moisture E3.3.4, E3.3.5, E3.3.6	Alternative Solution	<ul style="list-style-type: none"> <li>› Aluminium is impervious to moisture.</li> <li>› Installation is to E3/AS1.</li> </ul>
F2 Hazardous Building Materials F2.3.1	Alternative Solution	<ul style="list-style-type: none"> <li>› PE coating is inert once dry.</li> </ul>
G3 Food Preparation And Prevention Of Contamination G3.3.2 (A)	Alternative Solution	<ul style="list-style-type: none"> <li>› Panel is an impervious aluminium composite panel finished with a Polyethylene (PE) coating, comparable with materials referenced in paragraph 1.6 of G3/AS1.</li> </ul>

# 10. Additional Resources

---

## 10.1 Compliance and Information

For compliance & information of IBS Showerline refer to:

- IBS Showerline Warranty
- [www.ibs.co.nz](http://www.ibs.co.nz)
- 0800 367 759

## 10.2 Designing outside of scope

If the installation of IBS Showerline deviates from these specifications or the guidelines in this design and installation guide, please be aware that any warranty claims will be void, unless prior approval is obtained from IBS before starting the work.



# 11. Frequently Asked Questions

---

## **Q. What is IBS Showerline?**

- A. IBS Showerline is a popular wet wall lining panel that combines the strength and durability of an aluminium composite panel with a smooth and stylish curtain-coated paint finish.

## **Q. What are the benefits of using IBS Showerline?**

- A. IBS Showerline is impact-resistant, waterproof, mould-resistant, durable, easy to install, and easy to clean. It provides a consistent colour with a curtain-coated finish.

## **Q. Where can IBS Showerline be used?**

- A. IBS Showerline is suitable for use in bathrooms, including shower enclosures, kitchens, laundries, food preparation areas, and any other areas where easy clean-up is required.

## **Q. What sizes are available for IBS Showerline sheets**

- A. IBS Showerline sheets are available in the following sizes: 2400 x 900 x 4.75 mm, 2400 x 1200 x 4.75 mm.

## **Q. How do I install IBS Showerline?**

- A. IBS Showerline can be directly fixed to framing or over the top of most other substrates. It is important to follow the installation guide for detailed instructions.

## **Q. What tools are required for installing IBS Showerline?**

- A. Standard carpentry tools such as a hole saw, speed bits, drill, jig saw, scribing knife, utility knife, and bench saw or skill-saw/ equivalent with a tungsten carbide blade are required.

## **Q. How do I prepare the surface before installing IBS Showerline?**

- A. Ensure the surface is clean, dry, and free from any contaminants. Any existing coatings or finishes should be removed.

## **Q. Can IBS Showerline be used in wet areas?**

- A. Yes, IBS Showerline is designed for use in wet areas such as bathrooms and kitchens

**Q. What safety precautions should I take when installing IBS Showerline?**

- A. Work in a well-ventilated area, use dust masks and eye protection when cutting the sheets, and ensure the sheets are well-supported during cutting.

**Q. How should IBS Showerline sheets be stored before installation?**

- A. Store the sheets flat and off the ground in a dry, covered area to prevent warping and damage.

**Q. How do I clean and maintain IBS Showerline surfaces?**

- A. Clean with a mild detergent and water. Avoid using abrasive cleaners or tools that could damage the surface.

**Q. What is the warranty period for IBS Showerline?**

- A. The product comes with a warranty that covers defects in materials and workmanship for a period of 10 years.

**Q. What is the recommended adhesive for IBS Showerline?**

- A. Use a high-quality adhesive that is suitable for the substrate and follow the manufacturer's recommendations. See table 2 on page 15.

**Q. How do I handle and transport IBS Showerline sheets?**

- A. Handle with care to avoid damage. Transport the sheets flat and secure them to prevent movement, avoid pulling sheets on top of each other. Try and lift vertically and then move them to minimise any potential for scratching the surface.

**Q. What are the environmental benefits of using IBS Showerline?**

- A. IBS Showerline is made from sustainable materials and is designed to be durable, reducing the need for frequent replacements.

**Q. How do I ensure proper alignment and spacing when installing IBS Showerline?**

- A. Use a chalk line or laser level to mark guidelines on the substrate. Always ensure that the sheets are installed level and flush with the framing.

## 12. Limitations

---

When you are specifying and installing IBS Showerline the Installation Guide must be followed.

IBS Showerline should not be installed on timber framing where the moisture content is greater than 18%.

When used as a wall lining ensure stud centres do not exceed 600mm.

The overleaf installation checks are considered critical to the successful installation of IBS Showerline. Using this sheet as a checklist during installation will aid in problem free product installation and long term product durability post construction.

### **IMPORTANT NOTES:**

All sections of this checklist should be completed in full.

Careful adherence to technical specification literature is critically important for completing IBS Showerline wet wall lining installation. The installation shall comply with requirements of building consent. Any variations made should be approved by the BCA prior to work being undertaken.



# 13. Installation checklist

Installation checklist for IBS Showerline board based on the information available:

Items to be checked		✓ Tick <input type="checkbox"/>	Notes
<b>1. Pre-Installation Checks</b>			
1	Ensure the moisture content of timber framing is less than 18%.	<input type="checkbox"/>	
2	Ensure the substrate is level, clean, dry, and free from dust or debris.	<input type="checkbox"/>	
<b>2. Handling</b>			
3	Transport and handle IBS Showerline sheets carefully to avoid damage.	<input type="checkbox"/>	
4	Store sheets flat on a dry surface, covered to protect from dust and debris.	<input type="checkbox"/>	
<b>3. Cutting and Drilling</b>			
5	Use appropriate tools for cutting and drilling the boards to avoid damage.	<input type="checkbox"/>	
6	Always follow safety guidelines for dust and debris control.	<input type="checkbox"/>	
<b>4. Installation</b>			
7	Install boards in accordance with the IBS Showerline Installation Guide.	<input type="checkbox"/>	
8	Use the correct fasteners and adhesives compatible with IBS Showerline.	<input type="checkbox"/>	
<b>5. Fixing Sheets</b>			
9	Ensure sheets are properly fixed to the framing, with adequate support and spacing.	<input type="checkbox"/>	
<b>6. Dry Layout</b>			
10	Complete a dry layout to ensure proper placement and alignment of sheets.	<input type="checkbox"/>	

<b>Items to be checked</b>		<b>✓ Tick</b> <input type="checkbox"/>	<b>Notes</b>
<b>7. Adhesives and Sealants</b>			
11	Use recommended adhesives and sealants, and apply them correctly.	<input type="checkbox"/>	
<b>8. Trimming and Mouldings</b>			
12	Attach trims and mouldings with adhesive and sealant to prevent water ingress.	<input type="checkbox"/>	
<b>9. Create Openings</b>			
13	Carefully create openings for outlets and fixtures, ensuring clean and precise cuts.	<input type="checkbox"/>	
<b>10. Ceiling Layout</b>			
14	Follow specific guidelines for ceiling installation, including using tape and adhesive to support sheets.	<input type="checkbox"/>	
<b>11. Earth the sheets</b>			
15	For all sheets that have any power sockets or wires behind them ensure that you use an earthing lug.	<input type="checkbox"/>	
<b>12. After Installation Checks</b>			
16	Carefully remove the protective layer from the panels after the adhesive has cured.	<input type="checkbox"/>	
<b>13. Cleaning</b>			
17	Clean the panels with warm soapy water and avoid using abrasive cleaners.	<input type="checkbox"/>	
<b>14. Regular Maintenance</b>			
18	Regularly check for signs of wear or damage, and repair or replace panels as necessary.	<input type="checkbox"/>	



**Wetwall Lining**



**IBS Showerline**

**Design & Installation Guide**



Scan the QR code to view  
all IBS Showerline documents.

3 Zelian Drive, East Tamaki  
Auckland, New Zealand 2013

General Inquiries:

☎ 0800 367 759

✉ [info@ibs.co.nz](mailto:info@ibs.co.nz)

🌐 [www.ibs.co.nz](http://www.ibs.co.nz)